

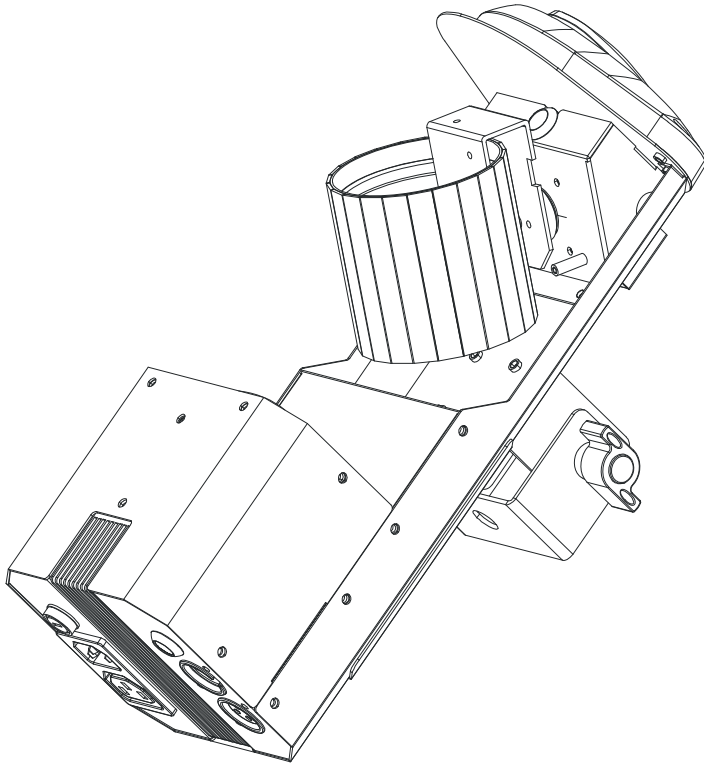

# INNO POCKET FUSION



## User Instructions

©2015 ADJ Products, LLC all rights reserved. Information, specifications, diagrams, images, and instructions herein are subject to change without notice. ADJ Products, LLC logo and identifying product names and numbers herein are trademarks of ADJ Products, LLC. Copyright protection claimed includes all forms and matters of copyrightable materials and information now allowed by statutory or judicial law or hereinafter granted. Product names used in this document may be trademarks or registered trademarks of their respective companies and are hereby acknowledged. All non-ADJ Products, LLC brands and product names are trademarks or registered trademarks of their respective companies.

**ADJ Products, LLC** and all affiliated companies hereby disclaim any and all liabilities for property, equipment, building, and electrical damages, injuries to any persons, and direct or indirect economic loss associated with the use or reliance of any information contained within this document, and/or as a result of the improper, unsafe, insufficient and negligent assembly, installation, rigging, and operation of this product.

Europe Energy Saving Notice

Energy Saving Matters (EuP 2009/125/EC)

Saving electric energy is a key to help protecting the environment. Please turn off all electrical products when they are not in use. To avoid power consumption in idle mode, disconnect all electrical equipment from power when not in use. Thank you!

## Inno Pocket Fusion

## General Information

**Unpacking:** Thank you for purchasing the Inno Pocket Fusion by ADJ Products, LLC. Every Inno Pocket Fusion has been thoroughly tested and has been shipped in perfect operating condition. Carefully check the shipping carton for damage that may have occurred during shipping. If the carton appears to be damaged, carefully inspect your fixture for any damage and be sure all equipment necessary to operate the unit has arrived intact. In the event damage has been found or parts are missing, please contact our toll free customer support number for further instructions. Please do not return this unit to your dealer without contacting customer support first.

**Introduction:** The Inno Pocket Fusion is a DMX intelligent Laser & LED barrel scanner. The Inno Pocket Fusion has three operating modes; a sound active, show mode, DMX controlled. The Inno Pocket Fusion can operate as a stand alone fixture or in a Master/Slave configuration. *For best results use fog or special effects smoke to enhance the beams projections.*

**Customer Support:** ADJ Products, LLC provides a toll free customer support line, to provide help and to answer any question should you encounter problems during your set up or initial operation. You may also visit us on the web at [www.adj.com](http://www.adj.com) for any comments or suggestions. Service Hours are Monday through Friday 8:00 a.m. to 4:30 p.m. Pacific Standard Time.

Voice: (800) 322-6337

Fax: (323) 582-2941

E-mail: [support@americandj.com](mailto:support@americandj.com)

To purchase parts online visit <http://parts.americandj.com>

**Warning!** To prevent or reduce the risk of electrical shock or fire, do not expose this unit to rain or moisture.

**Warning!** *This may cause severe eye damage. Avoid looking directly into the light source at all times!*

## Inno Pocket Fusion

## General Instructions

To optimize the performance of this product, please read these operating instructions carefully to familiarize yourself with the basic operations of this unit. These instructions contain important safety information regarding the use and maintenance of this unit. Please keep this manual with the unit, for future reference.

## Inno Pocket Fusion

## Features

- 5 DMX Channel Modes: 2/6/8/9/11
- 12W White LED & 4.9mW Green Laser (2-FX-1)
- 3 Operating Modes - Sound Active, Show Mode, & DMX Control
- Internal Microphone
- Digital Display for Address and Function Setting
- 8 Preprogrammed Shows
- Power Cord Daisy Chain (See page 30)
- UC IR Compatible (Sold Separately)

## Inno Pocket Fusion

## Warranty Registration

The Inno Pocket Fusion carries a 2 year (730 days) limited warranty. Please fill out the enclosed warranty card to validate your purchase and warranty. You may also register your product online at [www.americandj.com](http://www.americandj.com). All returned service items whether under warranty or not, must be freight pre-paid and accompany a return authorization (R.A.) number. If the unit is under warranty you must provide a copy of your proof of purchase invoice. Please contact ADJ customer support for a R.A. number.

## Inno Pocket Fusion

## Handling Precautions

**Caution!** There are no user serviceable parts inside this unit. Do not attempt any repairs yourself, doing so will void your manufactures warranty. In the unlikely event your unit may require service please contact ADJ Products, LLC.

*During operation the housing may become extremely hot. Avoid touching the unit with bare hands while in use.*

*ADJ Products, LLC will not accept any liability for any resulting damages caused by the non-observance of this manual or any unauthorized modification to this unit.*

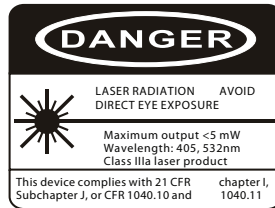

**Safety Issues:** This unit may “pop” the fuse if the maximum allotted load is reached.

- To reduce the risk of electrical shock or fire, do not expose this unit rain or moisture.
- Do not spill water or other liquids into or on to your unit.
- Do not attempt to remove or break off the ground prong from the electrical cord. This prong is used to reduce the risk of electrical shock and fire in case of an internal short. Do not attempt to operate this unit if the power cord has been frayed or broken.
- Disconnect from main power before making any type of connection.
- Do not remove the cover under any conditions. There are no user serviceable parts inside.
- Always be sure to mount this unit in an area that will allow proper ventilation. Allow about 6” (15cm) between this device and a wall.
- Do not attempt to operate this unit, if it becomes damaged.
- This unit is intended for indoor use only, use of this product outdoors voids all warranties.
- During long periods of non-use, disconnect the unit’s main power.
- Always mount this unit in safe and stable matter.
- Power cords should be routed so they are not likely to be walked on, pinched by items placed upon or against them.
- Cleaning -The fixture should be cleaned only as recommended by the manufacturer. See page 31 for cleaning details.
- Heat -The appliance should be situated away from heat sources such as radiators, heat registers, stoves, or other appliances (including amplifiers) that produce heat.
- The fixture should be serviced by qualified service personnel when:
  - A. The power-supply cord or the plug has been damaged.
  - B. Objects have fallen, or liquid has been spilled into the unit.
  - C. The unit has been exposed to rain or water.
  - D. The unit does not appear to operate normally or exhibits a marked change in performance.

### NON-INTERLOCKED HOUSING WARNING

The Inno Pocket Fusion contains high power laser devices internally. **Do not** open the laser housing, due to the potential exposure to unsafe levels of laser radiation. The laser power levels, if the unit is opened, can cause instant blindness, skin burns and fires.

### STOP AND READ ALL LASER SAFETY DATA OPERATION INSTRUCTIONS AND LASER SAFETY

The light source emitted from this product can potentially cause eye injury if not set up and used properly. The light source emitted from a laser is very different from any other light sources with which you may be aware of. Laser light is thousands of times more concentrated than any light from any other kind of light source. This concentration of light can cause instant eye injuries, primarily by burning the retina (the back of your eyeball containing cells that are sensitive to light). Even if you cannot feel “heat” from a laser beam, it can still potentially injure or blind you or your audience. Even very small amounts of laser beam light are potentially hazardous even at long distances. Laser eye injuries can be sustained faster than you can blink.

Do not think that because this laser splits the laser beam into hundreds of beams and that the laser beam is scanned out in high speed, that an individual laser beam is safe for eye exposure. This laser uses dozens of milliwatts of laser power (Class 3B levels internally) before it splits into multiple beams (Class 3R levels). Many of the individual beams are potentially hazardous to the eyes.

Do not think that because the laser light is moving, it is safe. This is not true. Nor, do the laser beams always move. Since eye injuries can occur instantly, it is critical to prevent even the smallest possibility of any direct eye exposure. In the laser safety regulation, it is not legal to aim Class 3R lasers in areas which people can get exposed. This is true even if it is aimed below people’s faces, such as on a dance floor.

**Do not operate the laser without first reading and understanding all safety and technical data in this manual.**

Always set up and install all laser effects so that all laser light is at least 3 meters (9.8 feet) above the floor on which people can stand.

After setting up, and before public use, test laser to ensure proper function. Do not use if any defect is detected. Do not use if laser emits only one or two laser beams rather than dozens/hundreds, as this could indicate damage to the diffraction grating optic, and could allow emission of higher laser levels above Class 3R.

**Do not** point lasers at people or animals. Never look into the laser aperture or laser beams.

**Do not** point lasers in areas in which people can potentially get exposed, such as uncontrolled balconies, etc.

**Do not** point lasers at highly reflective surfaces, such as windows, mirrors and shiny metal. Even laser reflections can be hazardous.

**Never** point a laser at aircraft, this is a federal offense.

**Never** point un-terminated laser beams into the sky.

**Do not** expose the output optic (aperture) to cleaning chemicals.

**Do not** use laser if the laser appears to be emitting only one or two beams.

**Do not** use the laser if the housing is damaged, the housing is open, or if the optics appear damaged in any way.

**Never** open the laser housing. The high laser power levels inside of the protective housing can start fires, burn skin and will cause instant eye injury.

**Never** leave this device running unattended.

The operation of a class 3R laser show is only allowed if the show is controlled by a skilled and well- trained operator, familiar with the data included in this manual.

The legal requirements for using laser entertainment products vary from country to country. The user is responsible for the legal requirements at the location/country of use.

Always use proper lighting safety cables when hanging lights and effects overhead.

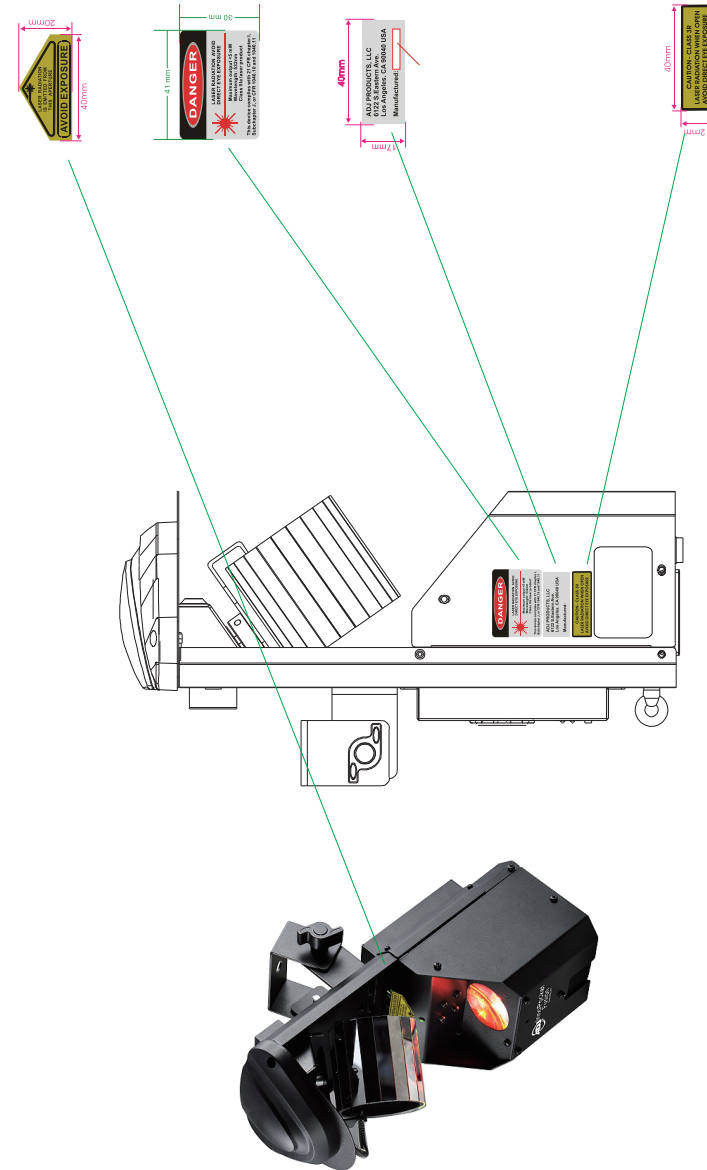

**Power Supply:** The ADJ Inno Pocket Fusion contains a automatic voltage switch, which will auto sense the voltage when it is plugged into a power source. With this switch there is no need to worry about the correct power voltage, this unit can be plugged in anywhere.

**DMX-512:** DMX is short for Digital Multiplex. This is a universal protocol used by most lighting and controller manufactures as a form of communication between intelligent fixtures and controllers. A DMX controller sends DMX data instructions from the controller to the fixture. DMX data is sent as serial data that travels from fixture to fixture via the DATA “IN” and DATA “OUT” XLR terminals located on all DMX fixtures (most controllers only have a DATA “OUT” terminal).

**DMX Linking:** DMX is a language allowing all makes and models of different manufactures to be linked together and operate from a single controller, as long as all fixtures and the controller are DMX compliant. *To ensure proper DMX data transmission, when using several DMX fixtures try to use the shortest cable path possible. The order in which fixtures are connected in a DMX line does not influence the DMX addressing. For example; a fixture assigned a DMX address of 1 may be placed anywhere in a DMX line, at the beginning, at the end, or anywhere in the middle. Therefore, the first fixture controlled by the controller could be the last fixture in the chain. When a fixture is assigned a DMX address of 1, the DMX controller knows to send DATA assigned to address 1 to that unit, no matter where it is located in the DMX chain.*

**Data Cable (DMX Cable) Requirements (For DMX and Master/Slave Operation):** The Inno Pocket Fusion can be controlled via DMX-512 protocol. The Inno Pocket Fusion has 5 DMX channel modes. The DMX address is set electronically using the controls on the front panel of the unit. Your unit and your DMX controller require a approved DMX-512 110 Ohm Data cable for data input and data output (Figure 1). We recommend Accu-Cable DMX cables. If you are making your own cables, be sure to use standard 110-120 Ohm shielded cable (This cable may be purchased at almost all professional sound and lighting stores). Your cables should be made with a male and female XLR connector on either end of the cable. Also remember that DMX



Figure 1

cable must be daisy chained and cannot be split.

**Notice:** Be sure to follow figures two and three when making your own cables. Do not use the ground lug on the XLR connector. Do not connect the cable’s shield conductor to the ground lug or allow the shield conductor to come in contact with the XLR’s outer casing. Grounding the shield could cause a short circuit and erratic behavior.

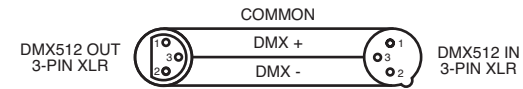

Figure 2

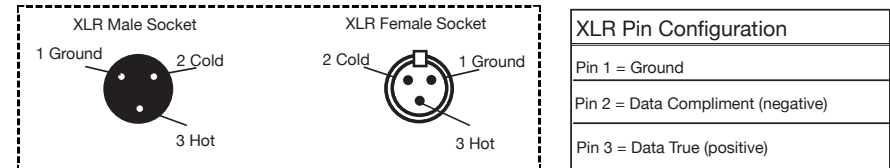

Figure 3

**Special Note: Line Termination.** When longer runs of cable are used, you may need to use a terminator on the last unit to avoid erratic behavior. A terminator is a 110-120 ohm 1/4 watt resistor which is connected between pins 2 and 3 of a male XLR connector (DATA + and DATA -). This unit is inserted in the female XLR connector of the last unit in your daisy chain to terminate the line. Using a cable terminator (ADJ part number Z-DMX/T) will decrease the possibilities of erratic behavior.



Termination reduces signal errors and avoids signal transmission problems and interference. It is always advisable to connect a DMX terminal, (Resistance 120 Ohm 1/4 W) between PIN 2 (DMX-) and PIN 3 (DMX +) of the last fixture.

Figure 4



**5-Pin XLR DMX Connectors.** Some manufactures use 5-pin DMX-512 data cables for DATA transmission in place of 3-pin. 5-pin DMX fixtures may be implemented in a 3-pin DMX line. When inserting standard 5-pin data cables in to a 3-pin line a cable adaptor must be used, these adaptors are readily available at most electric stores. The chart below details a proper cable conversion.

3-Pin XLR to 5-Pin XLR Conversion		
Conductor	3-Pin XLR Female (Out)	5-Pin XLR Male (In)
Ground/Shield	Pin 1	Pin 1
Data Compliment (- signal)	Pin 2	Pin 2
Data True (+ signal)	Pin 3	Pin 3
Not Used		Pin 4 - Do Not Use
Not Used		Pin 5 - Do Not Use

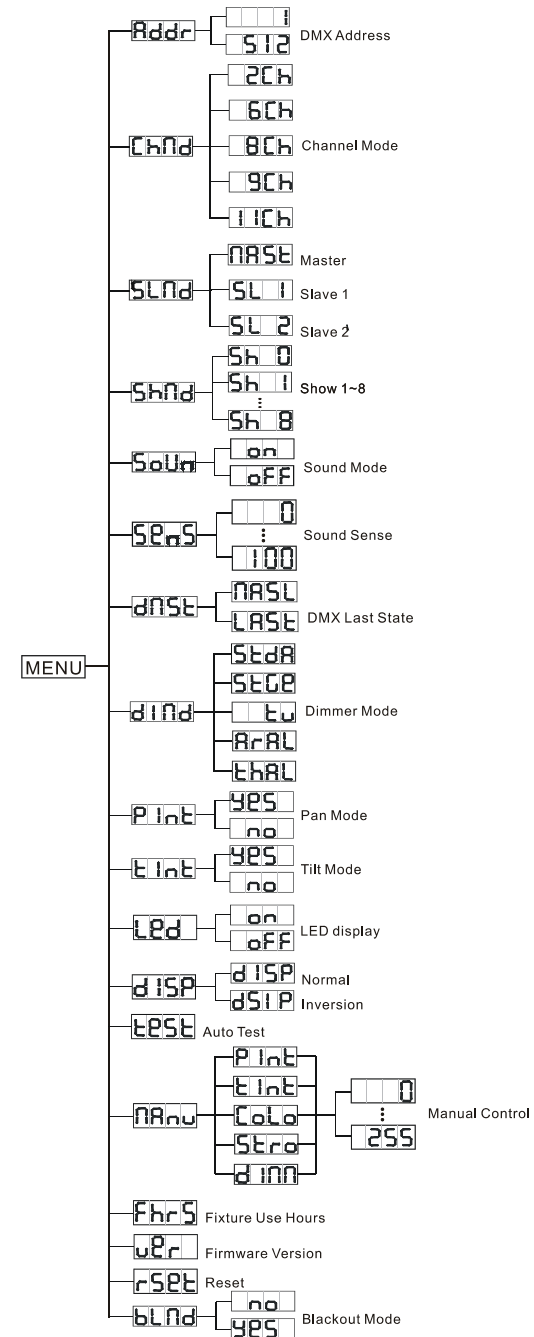

**ADDR - DMX Address Setting.**

1. Press the MENU button until “**ADDR**” is displayed, press ENTER.
2. The current address will now be displayed and flashing. Press the UP or DOWN buttons to find your desired address. When you have found your desired DMX address press ENTER then press and hold the MENU button for at least 3 seconds to set your desired DMX address.
3. Connect your DMX Controller.

**CHND - This will let select your desired DMX channel mode.**

1. Press the either the MENU button until “**CHND**” is displayed, press ENTER. Either “**2CH**”, “**6CH**”, “**8CH**”, “**9CH**”, or “**11CH**” will be displayed
2. Press the UP or DOWN buttons to choose your desired DMX mode and press ENTER to confirm and exit.

**SLND - This will let you set unit as a slave in a master-slave configuration.**

1. Press the MENU button until “**SLND**” is displayed, press ENTER. Either “**MAST**” “**SL 1**” or “**SL 2**” will be displayed.
2. Press the UP or DOWN buttons until your desired setting is displayed, and press ENTER to confirm.

**NOTE:** In a Master/Slave configuration you can set one fixture to Master and then set the next fixture to “**SL 2**”, the fixtures will now have contrast movement to each other.

**SHND: SH 0 - SH 8 - Show modes 0-8 (Factory programs). Show mode can run with or without sound active****mode active.**

1. Press the MENU button until “**SHND**” is displayed, press ENTER.
2. “Sh X” will now be displayed, “X” representing a number between 0-8. Programs 1-8 are factory programs, while “Sh 0” is random mode. Press the UP or DOWN buttons to find your desired show.
3. When you have found your desired show press ENTER, then press and hold the MENU button for at least 3 seconds to activate. After you have set your desired show, it can be changed at any time using the UP or DOWN buttons.

**SOUN - Sound Active mode.**

1. Press the MENU button until “**SOUN**” is displayed, press ENTER.
2. The display will show either “**ON**” or “**OFF**”. Press the UP or DOWN buttons to select “**ON**” to activate sound active mode, or “**OFF**” to deactivate sound active mode.
3. Press ENTER, then press and hold the MENU button for at least 3 seconds to activate.

**SENS - In this mode you can adjust the sound sensitivity.**

1. Press the MENU button until “**SENS**” is displayed, press ENTER.
2. A number between 0-100 will be displayed. Press the UP or DOWN buttons to adjust the sound sensitivity. 0 being the least sensitive, and 100 being the most sensitive.
3. When you have found your desired setting press ENTER to confirm.

**DNST** - This mode can be used as a precaution mode, that in case the DMX signal is lost, the operating mode chosen in the setup is the running mode the fixture will go into when the DMX signal is lost. You can also set this as the operating mode you would like the unit to return to when power is applied.

1. Press the MENU button until “**DNST**” is displayed, press ENTER.
2. Either “**MAST**” or “**LAST**” will be displayed. Choose an operating mode you would like the unit to start up in when power is applied or the DMX signal is lost.
  - **MAST** (Master Slave) - If the DMX signal is lost or power is applied, the unit will automatically go into Master Slave mode.
  - **LAST** (Last State) - If the DMX signal is lost the fixture will stay in the last DMX set up. If power is applied and this mode is set, the unit will automatically go into the last DMX set up.
3. Press ENTER to confirm your desired set up

**DIND** - In this mode you can select the dimmer curve.

1. Press the MENU button until “**DIND**” is displayed, press ENTER.
2. The current dimmer curve setting will be displayed.
3. Press the UP or DOWN buttons to find your desired dimmer curve and press ENTER to confirm. See the Dimmer Curve Chart on page 30 for more information.

**PINT** - Pan Inversion

1. Press the MENU button until “**PINT**” is displayed, press ENTER. Either Yes or No will be displayed.
2. To activate the Pan inversion press the UP or DOWN buttons

until YES is displayed, press ENTER to confirm. To deactivate Pan inversion, select NO and press Enter.

**TINT** - Tilt Inversion

1. Press the MENU button until “**TINT**” is displayed, press ENTER. Either YES or NO will be displayed.
2. To activate the Tilt inversion press the UP or DOWN buttons until YES is displayed, press ENTER to confirm. To deactivate Tilt inversion, select NO and press Enter.

**LED** - With this function you can have the LED display turn off after 10 seconds.

1. Press the MENU button until “**LED**” is displayed, press ENTER.
2. The display will show either “**ON**” or “**OFF**”. Press the UP or DOWN buttons to select “**ON**” to keep the LED display on at all times, or “**OFF**” to switch to have the LED display switch off after 10 seconds.
3. Press ENTER to confirm. To make the LED display reappear after it has turned off, press any button.

**DISP** - This function will reverse the display 180°.

1. Press the either the MENU button until “**DISP**” is displayed, press ENTER.
2. Press the UP button to select “**DSIP**” to “flip” the display, or “**DISP**” to change the display back.
3. Press ENTER to confirm.

**TEST** - This function will run a self test program. The test program will test pan/tilt movement and colors.



1. Press the MENU button until “**TEST**” is displayed, press ENTER.
2. The fixture will now run a self test. Press MENU to exit.

### **MANU** - In this submenu you are able to test the different functions; pan, tilt, colors, strobe, and dimmer.

1. Press the MENU button until “**MANU**” is displayed, press ENTER.
2. Use the UP and DOWN buttons to scroll through the various functions that are available for testing. Once you have found your desired function you would like to test press ENTER.
3. After you have pressed ENTER, use the UP and DOWN buttons to adjust the values and test the function. To exit press the MENU button.

### **FHRS** - With this function you can display the running time of the unit.

1. Press the MENU button until “**FHRS**” is displayed, press ENTER.
2. The running time of the fixture will now be displayed. Press MENU to exit.

### **VER** - With this function you can display the software version of the unit.

1. Press the MENU button until “**VER**” is displayed, press ENTER.
2. The software version will now be displayed. Press MENU to exit

### **RSET** - Use this function to reset the unit.

1. Press the MENU button until “**RSET**” is displayed, press ENTER.
2. The fixture will now reset.

### **BLND** - Blackout or Stand by mode.

1. Press the MENU button until “**BLND**” is displayed, press ENTER. Either Yes or No will be displayed.
2. To activate Blackout tap the UP or DOWN buttons until “Yes” is displayed, press ENTER to confirm. The fixture will now be in Blackout mode. To deactivate Blackout mode, select “No” and press Enter.

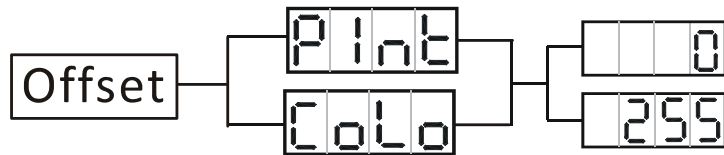

To enter the offset adjustment submenu, press the ENTER button for at least 5 seconds. In this submenu you are able to adjust the pan home position and gobo wheel position.

### PAN - Adjustment of the pan position.

1. Press the ENTER button for at least 5 seconds, then press the UP or DOWN buttons so that “**PAN**” is displayed, press ENTER.
2. Use the UP and DOWN buttons to make your adjustments, and then press ENTER to confirm. Press the MENU button for one second to exit.

### COLO - Adjustment of the color wheel position.

1. Press the ENTER button for at least 5 seconds, then press the UP or DOWN buttons so that “**COLO**” is displayed, press ENTER.
2. Use the UP and DOWN buttons to make your adjustments, and then press ENTER to confirm. Press the MENU button for one second to exit.

**Operating Modes:** The Inno Pocket Fusion can operate in three different modes. In each mode you can run the fixture as a stand alone fixture or in a master/slave configuration. This next section will detail the differences in the operating modes.

• **Sound Active mode -**

The fixture will react to sound, chasing through the built-in programs.

• **Show mode -**

The fixture will run one of 8 shows.

• **DMX control mode -**

This function will allow you to control each individual fixtures traits with a standard DMX-512 controller.

**Universal DMX Control:** This function allows you to use a universal DMX-512 controller to control the various features of you unit. A DMX controller allows you to create unique programs tailored to your individual needs.

1. The Inno Pocket Fusion has 5 DMX channel modes. See pages 22-29 for detailed description of the DMX values and traits.
2. To control your fixture in DMX mode, follow the set-up procedures on pages 5-7 as well as the set-up specifications that are included with your DMX controller.
3. Use your DMX controller’s faders to control the various DMX fixture traits.
4. Follow the instructions on page 12 to select your desired DMX channel mode and DMX address.
5. For longer cable runs (more than a 100 feet) use a terminator on the last fixture.
6. For help operating in DMX mode consult the manual included with your DMX controller.

**Sound Active Mode:** This mode allows either a single unit or several units linked together, to run to the beat of the music.

1. Press the MENU button until “**SOUN**” is displayed, and press ENTER. Press the UP or DOWN buttons so that “**ON**” is displayed and press ENTER.
2. To adjust the sound sensitivity level press the MENU button until “**SENS**” is displayed, and press ENTER. Use the UP or DOWN buttons to adjust the sensitivity level, “0” being least sensitive,

“100” being the most sensitive. Press ENTER to set your level.

**Show Mode:** This mode allows either a single unit or several units linked together, to run one of 8 shows that you choose. Show mode can run with or without sound active mode.

1. Press the MENU button until “**SHND**” is displayed, and press ENTER.
2. Press the UP or DOWN buttons until you find your desired show, press ENTER, then press and hold the MENU button for at least 3 seconds to activate. After you have set your desired show, it can be changed at any time using the UP or DOWN buttons.

**Master-Slave Configuration** This function will allow you to link up to 16 units together and operate without a controller. The units will be sound activated. In a Master-Slave set up, one unit will act as the controlling unit and the others will react to the controlling units programs. Any unit can act as a Master or as a Slave.

1. Using approved DMX data cables, daisy chain your units together via the XLR connector on the rear of the units. Remember the Male XLR connector is the input and the Female XLR connector is the output. The first unit in the chain (master) will use the female XLR connector only - The last unit in the chain will use the male XLR connector only. For longer cable runs we suggest a terminator at the last fixture.
2. Select your “Master” unit and press the MENU button until “**SLND**” is displayed, and Press ENTER. Using the UP or DOWN buttons, scroll to “**MAST**” and press ENTER. Next, set the “Master” unit to your desired operating mode.
3. On the slave units press the MENU button until “**SLND**” is displayed, and Press ENTER. Choose either “**SL 1**” or “**SL 2**” and press ENTER. See page 12 for more info.
4. The slave units will now follow the Master unit.

The **UC IR** infrared remote gives you control of various functions (See below). To control the fixture you must aim the remote at the front of the fixture and be no more than 30 feet away.

**STAND BY** - Pressing this button will blackout the fixture.

**FULL ON** - Hold this button down to fully light up the unit. When you let the button go, the unit will return to its previous state.

**FADE/GOBO** - Invalid for this fixture.

“**DIMMER +**” and “**DIMMER -**” - Use these buttons to adjust the output intensity and to adjust the strobe speed.

**STROBE** - Press and hold this button to activate strobing.

**COLOR** - Press this button and use buttons 1-9 to select your desired color. Press this button again to exit color selection.

**1-9** - When in color or show mode these buttons will allow you to select your desired color or show.

**SOUND ON & OFF** - These buttons activate and deactivate the sound active mode.

**SHOW** - This activates the show mode. Use buttons 1-9 to select your desired show.

Inno Pocket Fusion		2 DMX Channel Mode
Channel	Value	Function
1	0 - 7	SHOW OFF
	8 - 33	SHOW 1
	34 - 59	SHOW 2
	60 - 85	SHOW 3
	86 - 111	SHOW 4
	112 - 137	SHOW 5
	138 - 163	SHOW 6
	164 - 189	SHOW 7
	190 - 215	SHOW 8
	216 - 255	SOUND ACTIVE SHOW
2	0 - 255	SHOW SPEED/SOUND SENSITIVITY
	0 - 255	SHOW SPEED SLOW - FAST
	0 - 255	LEAST SENSITIVE - MOST SENSITIVE

When Channel 1 is between the values of 8-215, Channel 2 will control the show speed.

When Channel 1 is between the values of 216-255, Channel 2 will control the sound sensitivity.

Inno Pocket Fusion		6 DMX Channel Mode
Channel	Value	Function
1	0 - 7	SHOW OFF
	8 - 33	SHOW 1
	34 - 59	SHOW 2
	60 - 85	SHOW 3
	86 - 111	SHOW 4
	112 - 137	SHOW 5
	138 - 163	SHOW 6
	164 - 189	SHOW 7
	190 - 215	SHOW 8
	216 - 255	SOUND ACTIVE SHOW
2	0 - 255	SHOW SPEED/SOUND SENSITIVITY
	0 - 255	SHOW SPEED SLOW - FAST
	0 - 255	LEAST SENSITIVE - MOST SENSITIVE
3	0 - 7	LED STROBE
	8 - 15	BLACKOUT
	16 - 131	OPEN
	132 - 139	STROBING SLOW - FAST
	140 - 181	OPEN
	182 - 189	SLOW OPEN - FAST CLOSE
	190 - 231	OPEN
	232 - 239	FAST OPEN - SLOW CLOSE
	240 - 247	OPEN
	248 - 255	RANDOM STROBE
4	0 - 255	MASTER DIMMER 0% - 100%
5	0 - 7	LASER STROBE
	8 - 15	BLACKOUT
	16 - 131	OPEN
	132 - 239	STROBING SLOW - FAST
	240 - 247	OPEN
	248 - 255	RANDOM STROBE
6	0 - 89	RESET
	90 - 99	NULL
	100 - 255	RESET ALL
	100 - 255	NULL

Inno Pocket Fusion		8 DMX Channel Mode
Channel	Value	Function
1	0 - 255	PAN
2	0 - 255	TILT
3	0 - 7 8 - 15 16 - 23 24 - 31 32 - 39 40 - 47 48 - 55 56 - 63 64 - 71 72 - 79 80 - 87 88 - 95 96 - 103 104 - 111 112 - 127 128 - 255	COLOR WHEEL OPEN RED ORANGE YELLOW GREEN BLUE LIGHT BLUE PINK WHITE/RED RED/ORANGE ORANGE/YELLOW YELLOW/GREEN GREEN/BLUE BLUE/LIGHT BLUE LIGHT BLUE/PINK WHEEL ROTATION SLOW - FAST
4	0 - 7 8 - 15 16 - 131 132 - 139 140 - 181 182 - 189 190 - 231 232 - 239 240 - 247 248 - 255	LED STROBE BLACKOUT OPEN STROBING SLOW - FAST OPEN SLOW OPEN - FAST CLOSE OPEN FAST OPEN - SLOW CLOSE OPEN RANDOM STROBE OPEN
5	0 - 255	MASTER DIMMER 0% - 100%
6	0 - 9 10 - 120 121 - 135 136 - 245 246 - 255	LASER MOVEMENT STOP CLOCKWISE SLOW - FAST STOP COUNTER CLOCKWISE SLOW - FAST STOP

Inno Pocket Fusion		8 DMX Channel Mode
Channel	Value	Function
7	0 - 7 8 - 15 16 - 131 132 - 239 240 - 247 248 - 255	LASER STROBE BLACKOUT OPEN STROBING SLOW - FAST OPEN RANDOM STROBE OPEN
8	0 - 69 79 - 79 80 - 89 90 - 99 100 - 255	RESET NULL BLACKOUT W/ PAN MOVEMENT BLACKOUT W/ COLOR WHEEL MOVE RESET ALL NULL



Inno Pocket Fusion		9 DMX Channel Mode
Channel	Value	Function
1	0 - 255	PAN
2	0 - 255	TILT
3	0 - 7	COLOR WHEEL OPEN
	8 - 15	RED
	16 - 23	ORANGE
	24 - 31	YELLOW
	32 - 39	GREEN
	40 - 47	BLUE
	48 - 55	LIGHT BLUE
	56 - 63	PINK
	64 - 71	WHITE/RED
	72 - 79	RED/ORANGE
	80 - 87	ORANGE/YELLOW
	88 - 95	YELLOW/GREEN
	96 - 103	GREEN/BLUE
	104 - 111	BLUE/LIGHT BLUE
	112 - 127	LIGHT BLUE/PINK
128 - 255	WHEEL ROTATION SLOW - FAST	
4	0 - 7	LED STROBE BLACKOUT
	8 - 15	OPEN
	16 - 131	STROBING SLOW - FAST
	132 - 139	OPEN
	140 - 181	SLOW OPEN - FAST CLOSE
	182 - 189	OPEN
	190 - 231	FAST OPEN - SLOW CLOSE
	232 - 239	OPEN
	240 - 247	RANDOM STROBE
	248 - 255	OPEN
5	0 - 255	MASTER DIMMER 0% - 100%
6	0 - 9	LASER MOVEMENT STOP
	10 - 120	CLOCKWISE SLOW - FAST
	121 - 135	STOP
	136 - 245	COUNTER CLOCKWISE SLOW - FAST
	246 - 255	STOP

Inno Pocket Fusion		9 DMX Channel Mode
Channel	Value	Function
7	0 - 7	LASER STROBE
	8 - 15	BLACKOUT
	16 - 131	OPEN
	132 - 239	STROBING SLOW - FAST
	240 - 247	OPEN
8	248 - 255	RANDOM STROBE OPEN
	0 - 20	DIMMER MODE STANDARD
	21 - 40	STAGE
	41 - 60	TV
	61 - 80	ARCHITECTURAL
	81 - 100	THEATRE
101 - 255	DEFAULT DIMMER SETTING	
9	0 - 69	RESET
	79 - 79	NULL
	80 - 89	BLACKOUT W/ PAN MOVEMENT
	90 - 99	BLACKOUT W/ COLOR WHEEL MOVE
	100 - 255	RESET ALL
		NULL

Inno Pocket Fusion		11 DMX Channel Mode
Channel	Value	Function
1	0 - 255	PAN
2	0 - 255	TILT
3	0 - 7 8 - 15 16 - 23 24 - 31 32 - 39 40 - 47 48 - 55 56 - 63 64 - 71 72 - 79 80 - 87 88 - 95 96 - 103 104 - 111 112 - 127 128 - 255	COLOR WHEEL OPEN RED ORANGE YELLOW GREEN BLUE LIGHT BLUE PINK WHITE/RED RED/ORANGE ORANGE/YELLOW YELLOW/GREEN GREEN/BLUE BLUE/LIGHT BLUE LIGHT BLUE/PINK WHEEL ROTATION SLOW - FAST
4	0 - 7 8 - 15 16 - 131 132 - 139 140 - 181 182 - 189 190 - 231 232 - 239 240 - 247 248 - 255	LED STROBE BLACKOUT OPEN STROBING SLOW - FAST OPEN SLOW OPEN - FAST CLOSE OPEN FAST OPEN - SLOW CLOSE OPEN RANDOM STROBE OPEN
5	0 - 255	MASTER DIMMER 0% - 100%
6	0 - 9 10 - 120 121 - 135 136 - 245 246 - 255	LASER MOVEMENT STOP CLOCKWISE SLOW - FAST STOP COUNTER CLOCKWISE SLOW - FAST STOP

Inno Pocket Fusion		11 DMX Channel Mode
Channel	Value	Function
7	0 - 7 8 - 15 16 - 131 132 - 239 240 - 247 248 - 255	LASER STROBE BLACKOUT OPEN STROBING SLOW - FAST OPEN RANDOM STROBE OPEN
8	0 - 7 8 - 33 34 - 59 60 - 85 86 - 111 112 - 137 138 - 163 164 - 189 190 - 215 216 - 255	SHOW OFF SHOW 1 SHOW 2 SHOW 3 SHOW 4 SHOW 5 SHOW 6 SHOW 7 SHOW 8 SOUND ACTIVE SHOW
9	0 - 255 0 - 255	SHOW SPEED/SOUND SENSITIVITY SHOW SPEED SLOW - FAST LEAST SENSITIVE - MOST SENSITIVE
10	0 - 20 21 - 40 41 - 60 61 - 80 81 - 100 101 - 255	DIMMER MODE STANDARD STAGE TV ARCHITECTURAL THEATRE DEFAULT DIMMER SETTING
11	0 - 69 79 - 79 80 - 89 90 - 99 100 - 255	RESET NULL BLACKOUT W/ PAN MOVEMENT BLACKOUT W/ COLOR WHEEL MOVE RESET ALL NULL

## Inno Pocket Fusion

## Power Cord Daisy Chain

**With this feature you can connect the fixtures to one another using the IEC input and output sockets. The quantity that can be connected is 22 fixtures maximum for 120V and 38 fixtures maximum for 240V. After the maximum fixtures has been reached you will need to use a new power outlet. They must be the same fixtures. DO NOT mix fixtures.**

## Inno Pocket Fusion

## Photometric Chart

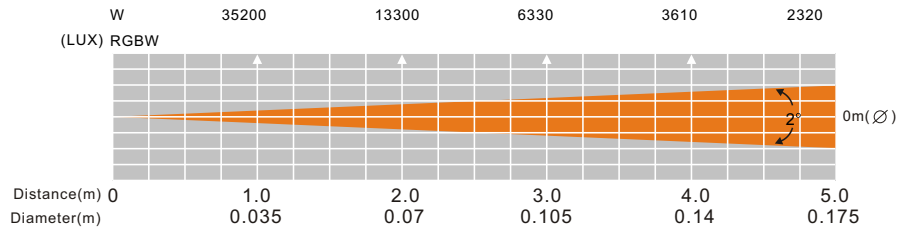

## Inno Pocket Fusion

## Dimmer Curve Chart

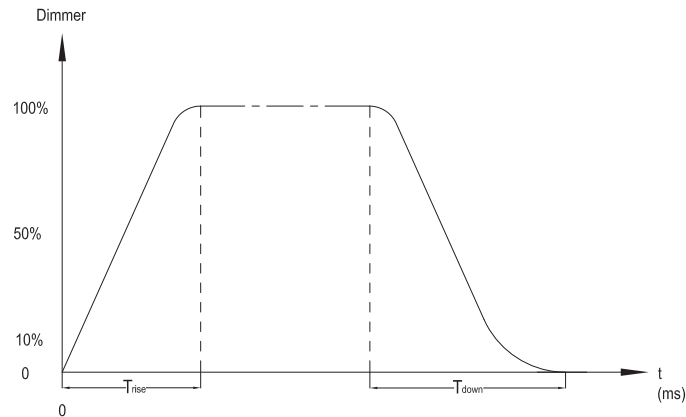

Ramp Effect	0 $\frac{255}{}$ 0S (Fade Time)		0 $\frac{255}{}$ 1S (Fade Time)	
	$T_{rise}$ (ms)	$T_{down}$ (ms)	$T_{rise}$ (ms)	$T_{down}$ (ms)
Standard	0	0	0	0
Stage	780	1100	1540	1660
TV	1180	1520	1860	1940
Architectural	1380	1730	2040	2120
Theatre	1580	1940	2230	2280

## Inno Pocket Fusion

## Fuse Replacement

Unplug the unit from any power source it may be connected to. Using a phillips-head screw driver remove the fuse holder located on the bottom of the unit next to the I.E.C. plugs. Remove the bad fuse and replace with a new one.

## Inno Pocket Fusion

## Cleaning

**Fixture Cleaning:** Due to fog residue, smoke, and dust cleaning the internal and external optical lenses and mirror should be carried out periodically to optimize light output. Cleaning frequency depends on the environment in which the fixture operates (I.e. smoke, fog residue, dust, dew). In heavy club use we recommend cleaning on a monthly basis. Periodic cleaning will ensure longevity, and crisp output.

1. Use normal glass cleaner and a soft cloth to wipe down the outside casing.
2. Use a brush to wipe down the cooling vents and fan grill.
3. Clean the external optics with glass cleaner and a soft cloth every 20 days.
4. Clean the internal optics with glass cleaner and a soft cloth every 30-60 days.
5. Always be sure to dry all parts completely before plugging the unit back in.

## Inno Pocket Fusion

## Trouble Shooting

**Trouble Shooting:** Listed below are a few common problems that you may encounter, with solutions.

### No light output from the unit;

1. Be sure the external fuse has not blown. The fuse is located on the rear of the unit.
2. Be sure the fuse holder is completely and properly seated.

### Unit does not respond to sound;

1. Low frequencies (bass) should cause the unit to react to sound. Tapping on the microphone, quiet or high pitched sounds may not activate the unit.

## MANUFACTURER'S LIMITED WARRANTY

- A. ADJ Products, LLC hereby warrants, to the original purchaser, ADJ Products, LLC products to be free of manufacturing defects in material and workmanship for a prescribed period from the date of purchase (see specific warranty period on reverse). This warranty shall be valid only if the product is purchased within the United States of America, including possessions and territories. It is the owner's responsibility to establish the date and place of purchase by acceptable evidence, at the time service is sought.
- B. **For warranty service you must obtain a Return Authorization number (RA#) before sending back the product—please contact ADJ Products, LLC Service Department at 800-322-6337.** Send the product only to the ADJ Products, LLC factory. All shipping charges must be pre-paid. If the requested repairs or service (including parts replacement) are within the terms of this warranty, ADJ Products, LLC will pay return shipping charges only to a designated point within the United States. If the entire instrument is sent, it must be shipped in its original package. No accessories should be shipped with the product. If any accessories are shipped with the product, ADJ Products, LLC shall have no liability whatsoever for loss of or damage to any such accessories, nor for the safe return thereof.
- C. This warranty is void if the serial number has been altered or removed; if the product is modified in any manner which ADJ Products, LLC concludes, after inspection, affects the reliability of the product; if the product has been repaired or serviced by anyone other than the ADJ Products, LLC factory unless prior written authorization was issued to purchaser by ADJ Products, LLC; if the product is damaged because not properly maintained as set forth in the instruction manual.
- D. This is not a service contract, and this warranty does not include maintenance, cleaning or periodic check up. During the period specified above, ADJ Products, LLC will replace defective parts at its expense with new or refurbished parts, and will absorb all expenses for warranty service and repair labor by reason of defects in material or workmanship. The sole responsibility of ADJ Products, LLC under this warranty shall be limited to the repair of the product, or replacement thereof, including parts, at the sole discretion of ADJ Products, LLC. All products covered by this warranty were manufactured after August 15, 2012, and bear indentifying marks to that effect.
- E. ADJ Products, LLC reserves the right to make changes in design and/or improvements upon its products without any obligation to include these changes in any products theretofore manufactured.

No warranty, whether expressed or implied, is given or made with respect to any accessory supplied with products described above. Except to the extent prohibited by applicable law, all implied warranties made by ADJ Products, LLC in connection with this product, including warranties of merchantability or fitness, are limited in duration to the warranty period set forth above. And no warranties, whether expressed or implied, including warranties of merchantability or fitness, shall apply to this product after said period has expired. The consumer's and/or Dealer's sole remedy shall be such repair or replacement as is expressly provided above; and under no circumstances shall ADJ Products, LLC be liable for any loss or damage, direct or consequential, arising out of the use of, or inability to use, this product.

This warranty is the only written warranty applicable to ADJ Products, LLC Products and supersedes all prior warranties and written descriptions of warranty terms and conditions heretofore published.

## MANUFACTURER'S LIMITED WARRANTY PERIODS:

- **Lighting Products = 1-year (365 days) Limited Warranty** (Such as: Special Effect Lighting, Intelligent Lighting, UV lighting, Strobes, Fog Machines, Bubble Machines, Mirror Balls, Par Cans, Trussing, Lighting Stands etc. excluding LED and lamps)
  - **Laser Products = 1 Year (365 Days) Limited Warranty** (excluding laser diodes which have a 6 month limited warranty)
  - **L.E.D. Products = 2-year (730 days) Limited Warranty** (excluding motors, PCB boards, and power supplies, which have a 1-year (365 day Limited Warranty) batteries which have a 180 day limited warranty). Only the L.E.D.s carry a 2-year warranty (excluding StarTec Series which carries a 90 Day Limited Warranty)
  - **ADJ DMX Controllers = 2 Year (730 Days) Limited Warranty** (excluding faders and tact switches)
- ADJ Products, LLC - [www.adj.com](http://www.adj.com) - Inno Pocket Fusion Instruction Manual Page 32

**Inno Pocket Fusion****Specifications**

<b>Model:</b>	<b>Inno Pocket Fusion</b>
<b>Voltage:</b>	100V ~ 240V/50~60Hz
<b>LED:</b>	1 x 12W White LED
<b>Laser:</b>	4.9mW Green Lase Diode
<b>Power Consumption:</b>	32W
<b>Power Cord Daisy Chain:</b>	22 Fixtures Max. (120V) 38 Fixtures Max. (230V)
<b>Dimensions:</b>	13.5”(L) x 5.25”(W) x 7”(H) 340 x 132 x 177mm
<b>Weight:</b>	7.5 Lbs. / 3.4 kgs.
<b>Beam Angle:</b>	2 Degree (LED Output) 5 Degree (LED & Laser Output)
<b>Fuse:</b>	2 Amp
<b>Duty Cycle:</b>	None
<b>DMX:</b>	5 DMX Channel Modes: 2/6/8/9/11
<b>Colors:</b>	7 Colors + Spot
<b>Sound Active:</b>	Yes
<b>Working Position:</b>	Any Safe, Secure Position
<b>Warranty:</b>	2 Year (730 days)

**Auto Sensing Voltage:** *This fixture contains a automatic voltage switch, which will auto sense the voltage when it is plugged into the power source.*

**Please Note:** *Specifications and improvements in the design of this unit and this manual are subject to change without any prior written notice.*

ADJ Products, LLC  
6122 S. Eastern Ave. Los Angeles, CA 90040 USA  
Tel: 323-582-2650 / Fax: 323-725-6100  
Web: [www.adj.com](http://www.adj.com) / E-mail: [info@americandj.com](mailto:info@americandj.com)

A.D.J. Supply Europe B.V.  
Junostraat 2  
6468 EW Kerkrade  
Netherlands

Follow Us On:



[facebook.com/americandj](https://facebook.com/americandj)  
[twitter.com/americandj](https://twitter.com/americandj)  
[youtube.com/adjlighting](https://youtube.com/adjlighting)

[service@adjgroup.eu](mailto:service@adjgroup.eu) / [www.adj.eu](http://www.adj.eu)  
Tel: +31 45 546 85 00 / Fax: +31 45 546 85 99