

XLogic Alpha-Link

AX / MADI-AX / MADI-SX / LIVE

User Guide

XLogic Alpha-Link. This is SSL.

Solid State Logic
S O U N D | | V I S I O N

Document History

| | | |
|-----------|-----------------|--|
| 82BSAM01A | (April 2010) | Initial release |
| 82BSAM01B | (February 2011) | Added various video sync notes plus other assorted corrections |
| 82BSAM01C | (October 2011) | Clarified Routing Matrix Control, settings for the wordclock output at 2Fs corrected |

Contents

| | | | |
|--|--------------------|---|--------------------|
| Introduction | 1 | Virtual Switches, Page One (Alpha-Link AX, MADI-AX and MADI-SX) | 14 |
| Scope | 2 | Virtual Switches, Page One (Alpha-Link LIVE) | 15 |
| I/O Capabilities | 3 | Notes for Virtual Switches, Page One | 16 |
| Installation Notes | 4 | Virtual Switches, Page Two (Alpha-Link AX and MADI-AX) | 18 |
| Front Panel | 5 | Virtual Switches, Page Two (Alpha-Link MADI-SX and LIVE) | 19 |
| Power Switch | 5 | Notes for Virtual Switches, Page Two | 20 |
| Headphones | 6 | Virtual Switches, Page Three (Alpha-Link MADI-SX and LIVE) | 21 |
| Routing Matrix Control | 6 | Notes for Virtual Switches, Page Three | 22 |
| Viewing and Setting Routing | 7 | Appendix A – AES/EBU Interface | 23 |
| Clock Source Selection | 8 | Inputs with Sample Rate Conversion | 23 |
| Sample Rate Selection | 9 | Input Sample Rate and Auxiliary Data | 23 |
| Signal Meters | 10 | Inputs without Sample Rate Conversion | 23 |
| System Settings and Diagnostics | 11 | Output Auxiliary Data | 23 |
| Diagnostic Mode | 11 | Appendix B – Troubleshooting | 24 |
| Picking a Page of Virtual Switches | 11 | Support FAQs | 25 |
| Selecting an Option | 12 | Appendix C – Alpha-Link Model Numbers | 27 |
| Setting an Option | 12 | | |
| Firmware Version | 13 | | |
| Current Firmware Versions | 13 | | |



Introduction

Congratulations on your purchase of this Solid State Logic Alpha-Link Audio I/O unit. Please be assured that it will provide you with many years of reliable service while delivering the pristine audio quality you expect from any Solid State Logic product.

The Alpha-Link Audio I/O Product Range are stylishly designed, 2U-high rack-mountable units providing fully featured multi-channel audio converters for Studio, Live and Broadcast Applications with an incredible price/performance ratio. There are four Alpha-Link models, all featuring high quality 24-channel SSL enhanced AD/DA converter circuitry and offering a choice of digital audio format options.

- The Alpha-Link AX and Alpha-Link MADI-AX are ADAT based converters
- The Alpha-Link MADI-SX is a MADI & AES/EBU based converter
- The Alpha-Link LIVE is a MADI & AES/EBU based converter which offers dual power supplies and features control ports for up to three Alpha-Link 8-RMP Mic preamps. Two configurations of Alpha-Link LIVE are available to suit either European or US broadcast analogue interface levels.

Each unit offers simple front panel controls to control unit configuration and the comprehensive input/output routing matrix which can be used to set up global connections between the various I/O connections and makes all combinations possible. There is also a handy front panel headphone connection (Alpha-Link LIVE excepted) plus a meter section for the analogue inputs and outputs with an AD/DA selection button, mode indicator LEDs and 24 tri-colour level LEDs.

All Alpha-Link units can be used as standalone format converters, but used in combination with an SSL Mixpander PCI card they provide a powerful, highly flexible IO solution for native PC-based audio workstations. When the unit is connected to a Mixpander card the inputs and outputs can be routed individually from the PC using the SSL Mixer software. When the Alpha-Link LIVE is connected to an SSL C10 HD broadcast console, remote control of up to three Alpha-Link 8-RMP Mic preamps is possible.

Scope

This User Guide should be read in conjunction with the Alpha-Link Installation Guide. This guide covers the configuration, features and operation of your Alpha-Link unit whilst the Installation Guide provides all of the information required to install and interface to your new unit. As with the Installation Guide, the information in this User Guide generally applies to all the models in the XLogic Alpha-Link range:

- Alpha-Link AX
- Alpha-Link MADI-AX
- Alpha-Link MADI-SX
- Alpha-Link LIVE

Throughout this guide, these units are all collectively referred to as the 'Alpha-Link'. References to particular audio interfaces (MADI, ADAT, AES/EBU or analogue) obviously apply only to the Alpha-Link models that support the interface.

IMPORTANT

Please register your XLogic Alpha-Link unit on our website. This will ensure that you receive notification of future updates and other important information, and that your guarantee is registered. Registration will also make you eligible for technical support.

The Solid State Logic home page is at: www.solidstatelogic.com

From there you can access our Support page, which includes links to the Product Registration and Download pages. You can also visit the Frequently Asked Questions (FAQ) area for any questions you might have or to contact our Technical Support staff.

I/O Capabilities

The number of channels available on each audio interface provided by the Alpha-Link is determined by the sample rate and in certain circumstances by the mode of operation chosen.

Each unit can operate at one of four nominal sample rates; 44.1kHz, 48kHz, 88.2kHz and 96kHz. If locked to an external clock source, each unit can also operate at a deviation of up to $\pm 10\%$ from these rates. Throughout this guide we will often refer to the lower set of sample rates (44.1kHz, 48kHz) collectively as 'Fs' whilst the higher rates, being twice the lower set, will be referred to as '2Fs'.

Early digital audio interfaces designed to run at 2Fs rates did so by modifying the way that data is packed into the digital audio stream without increasing the actual transmission rate. This leads to a lower channel count for a given interface but results in a 2Fs interface that is broadly compatible with the original Fs rate interface. Later improvements for some interface types lead to 'proper' double speed 2Fs interfaces that did not compromise the channel count but were no longer compatible with older Fs rate interfaces. These developments resulted in two different modes of operation at the higher 2Fs rates; 'Legacy' or 'SMUX' and 'High Speed'. The channel count differences are loosely summarised in the following table and further information will be found towards the rear of this guide.

| Audio Interface | Sample Rate and Mode | | |
|-----------------|---|-------------------|-------------------|
| | Fs | 2Fs (Legacy/SMUX) | 2Fs (High Speed) |
| ADAT | 24 Channels | 12 Channels | n/a |
| AES/EBU | 24 Channels | 12 Channels | 24 Channels |
| Analogue | 24 Channels – irrespective of sample rate | | |
| Expansion Port | 64 Channels – irrespective of sample rate | | |
| MADI | 56 or 64 Channels | 28 or 32 Channels | 28 or 32 Channels |

Installation Notes

Please take time to read through this guide before installing your Alpha-Link. If however you are unable to resist that temptation, do take note of the following points:

- Full connector pin-out details are provided in the Installation Guide.
- The nominal analogue I/O level of each Alpha-Link is +22dBu \approx 0dB FS apart from Alpha-Link LIVE which is factory configured for either +18dBu or +24dBu \approx 0dB FS (see also **Appendix C** for unit identification).
- Your Alpha-Link unit can be rack mounted. Whilst the unit occupies 2U of rack space in a standard 19-inch rack, do please leave (a 1U) space above and below the unit for cooling.
- It may be necessary to change the default **CLOCK SOURCE** – please refer to the **Clock Source Selection** discussion on page 8 for further details.
- Please turn down, switch off or disconnect any connected amplifiers before re-configuring your Alpha-Link. Changing signal routing and/or clock source can potentially produce loud audible clicks.
- To use an Alpha-Link unit with an SSL (or Soundscape) Mixpander PCI audio card, connect the Expansion Bus port of the Alpha-Link unit to the Expansion Bus port of the Mixpander card using a Mixpander Expansion Bus cable.

WARNING!

Where applicable, always switch the host computer and the Alpha-Link unit off before connecting or disconnecting the Mixpander Expansion Bus cable or damage may result.

- If connected to a Mixpander card, switch the computer that hosts the Mixpander card on and start the SSL Mixer software *before* applying power to the Alpha-Link unit.

Front Panel

The front panels of each model of Alpha-Link are all broadly similar, differing only to reflect the different I/O options provided (the unit illustrated here being an Alpha-Link MADI-SX).

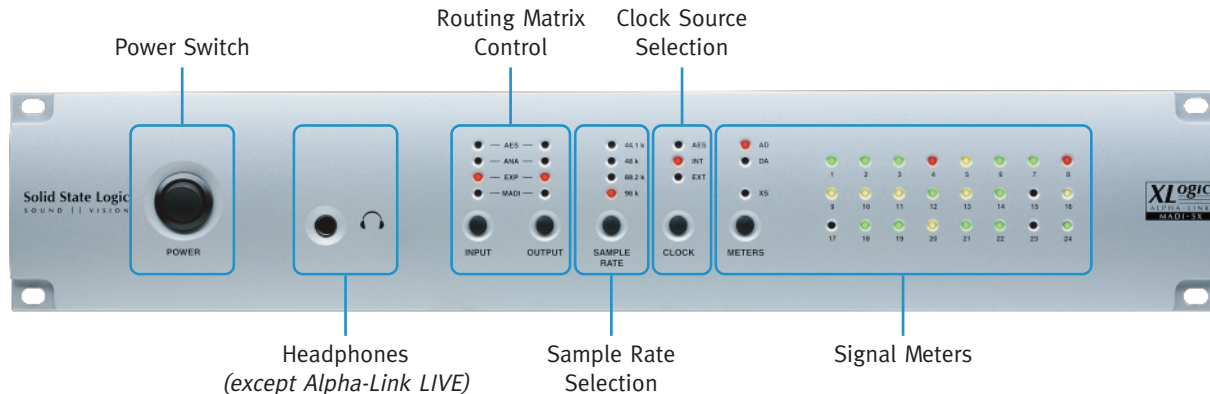

Power Switch

This is used to switch the Alpha-Link on or off.

The current front panel settings are stored in non-volatile memory when the unit is switched off, and recalled the next time it is switched on. When the Alpha-Link is used in combination with an SSL (or Soundscape) Mixpander card the SSL Mixer software controls all front panel settings and the settings defined in the software will be restored as soon as the unit is powered up again (if still connected to the Mixpander card).

Headphones

A headphone socket is provided on all units apart from the Alpha-Link LIVE. This connector is a standard 0.25" headphone jack socket and provides a stereo signal derived from analogue output channels 23 (Left) and 24 (Right).

The headphone signal level is fixed and can only be controlled in the digital domain by a suitable controller such as the SSL Mixer software via an SSL (or Soundscape) Mixpander card.

Routing Matrix Control

Alpha-Link contains a routing matrix to route groups of signals between the inputs and outputs. This matrix is controlled using two buttons – one for **INPUT**, one for **OUTPUT** – along with a set of indicator LEDs. Using these two buttons, any input group (ADAT or AES/EBU, Analogue, Expansion Bus or MADi) can be connected to any output group.

The Inputs and Outputs of each type of I/O are routed *independantly* – routing Analogue In → MADi Out *will not* also route MADi In → Analogue Out for example!

If Alpha-Link is connected to a Mixpander card it can act as multi-channel bi-directional format converter between the inputs and outputs and the Expansion Bus. All routing in this case is determined by the SSL Mixer software and the front panel routing matrix control is deactivated.

However the input and output signals are routed in the Alpha-Link, all routing is performed to full 24-bit precision. There are no mixing functions in Alpha-Link so whilst it is possible to use the routing matrix to route any single input to multiple outputs, it is not possible for a single output to be fed from more than one input (selecting a second source for an output will cause the second source to *replace* the original).

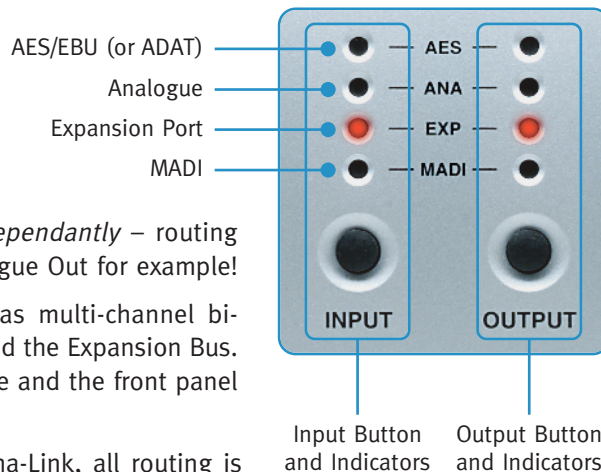

Viewing and Setting Routing

Pressing the **OUTPUT** button repeatedly will cycle through the available output groups, the currently selected output group being indicated by the corresponding LED. For each output group, the LEDs of the input column will indicate which input group(s) are connected to that output group. To set or change the input group(s) connected to a given output group:

- Use the **OUTPUT** button to select the required output.
- Press *and hold* the **OUTPUT** button.
- With the **OUTPUT** button held, each press of the **INPUT** button will step through each possible input group for that output.
- Once the required routing has been selected, releasing the **OUTPUT** button will store and activate your selection.

*Please note that the **INPUT** button works only in combination with the **OUTPUT** button.*

Where capacity is available, two input groups may be assigned to one output group – the AES and analogue input groups of an Alpha-Link MADI-SX or LIVE for example can both connect to the MADI output group. Where this is possible it will be indicated by illuminating both input group LEDs whilst stepping through the different modes.

*In cases where two input groups are connected to a single output group, the order in which input groups are assigned is determined by the ‘Connection Mode’ described in the **System Settings and Diagnostics** section of this guide. Channels will be routed in order, hence the ‘lower’ input group will be fully used before the routing spills over to the ‘higher’ group. Where this split occurs will depend on the sample rate and channel count and may result in some channels remaining unused or un-routed.*

Clock Source Selection

The Alpha-Link unit can operate either as a Clock Master device ('Internal' mode), or as a Clock Slave device locked to an external clock signal.

Possible external sources are:

- ADAT (Alpha-Link AX and MADI-AX)
- AES/EBU (Alpha-Link MADI-SX and LIVE)
- MADI (Alpha-Link MADI-AX, MADI-SX and LIVE)
- Video (Alpha-Link MADI-SX and LIVE, *with hardware modification*)
- Wordclock (all units)

Pressing the **CLOCK** button will step through each of the possible options, each illuminating the corresponding LED. When the button is released, the entire Alpha-Link will lock to that source. Note that a flashing clock LED indicates that although the corresponding mode has been selected, the Alpha-Link is not receiving a valid Master Clock signal via the selected port/input.

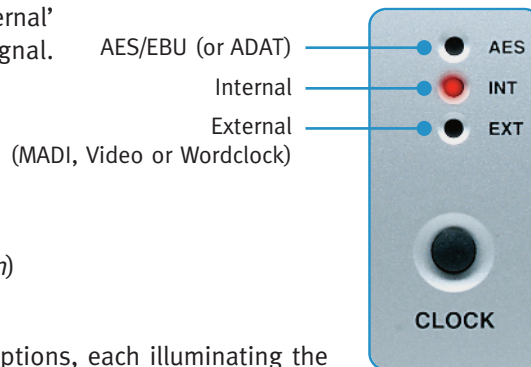

*If either ADAT or AES/EBU are selected as an external clock source, it may be necessary to preset which ADAT port – or AES/EBU input (port A only) – is used to derive the clock signal from. In the same manner, the ‘External’ source – MADI or Wordclock – must also be preset. Please refer to the **System Settings and Diagnostics** section of this guide for details of how to preset these clock sources.*

When the Alpha-Link unit is used as part of a Mixpander setup, the **CLOCK** button will be disabled and the clock source must be selected in the SSL Mixer software. Note however that the Mixpander card only operates as a Clock Slave and therefore it is the Alpha-Link which provides a clock signal to the Mixpander card.

Alpha-Link LIVE units are preconfigured to receive an external clock extracted from the incoming MADI stream

Sample Rate Selection

The sample rate indicators show the current sample rate of the unit. When the Alpha-Link clock source is set to 'Internal' (see opposite), pressing the **SAMPLE RATE** button will step through each available sample rate (44.1kHz, 48kHz, 88.2kHz and 96kHz) – as indicated by the corresponding LEDs.

When the clock source is set to an 'external' source (ADAT, AES/EBU, External or MADI – the possible options depend on the particular Alpha-Link model) the illuminated LED indicates the sample rate being received from that source. If there is an error or if the received sample rate falls outside of the tolerance expected ($\pm 0.5\%$ from nominal), all sample rate LEDs will be off.

When locking to an 'external' source Alpha-Link will normally accept and lock to a wider clock range at up to $\pm 10\%$ of the nominal rate, provided that the nominal rate corresponds to one of the supported rates (44.1kHz, 48kHz, 88.2kHz and 96kHz). As noted above, if the sample rate from an external source falls outside of the expected tolerance *all* sample rate LEDs will be extinguished although the clock source LED should still indicate if a valid signal is being received.

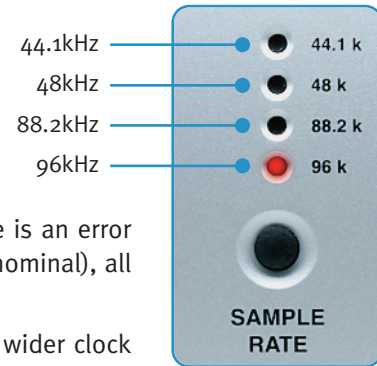

If the unit has been set to interface the maximum 64 MADI channels (32 channels at higher sample rates), the tighter clock tolerance of $\pm 0.5\%$ applies.

If the Alpha-Link is used in combination with a Mixpander card the **SAMPLE RATE** button will be deactivated and the sample rate LEDs will reflect the clock source and sample rate settings made in the SSL Mixer software.

If pressing the Sample Rate button has no effect – and the unit is not connected to a Mixpander card – check that the clock source is set to 'Internal'.

Signal Meters

The meter section of the front panel provides simple tri-colour LED metering for either the 24 analogue inputs (AD) or the 24 analogue outputs (DA), selectable using the **METERS** button.



For each input or output channel, the signal level is represented by the state of the LED with the corresponding number. The LEDs respond to the signal level in the digital domain (in dB FS) as follows:

- OFF < -30dB FS (less than -8dBu applied to an analogue input; -12dBu or -6dBu for Alpha-Link LIVE)
- GREEN > -30dB FS (greater than -8dBu applied to an analogue input; -12dBu or -6dBu for Alpha-Link LIVE)
- AMBER > -3.0dB FS (greater than $+19\text{dBu}$ applied to an analogue input; $+15\text{dBu}$ or $+21\text{dBu}$ for Alpha-Link LIVE)
- RED > -0.1dB FS ($+22\text{dBu}$ or more applied to an analogue input; $+18\text{dBu}$ or $+24\text{dBu}$ for Alpha-Link LIVE)

*Whilst the XS LED is located in this area of the front panel, it has no metering function – its use is described in the **System Settings and Diagnostics** section of this guide.*

System Settings and Diagnostics

Each Alpha-Link unit is configured by default to work in a simple system. Many users however may find that these defaults are not appropriate for their setup. To cater for such situations the default settings may be adjusted using a set of virtual switches, accessed from the Alpha-Link front panel by placing the unit into a diagnostic mode. These virtual switch settings are non-volatile and are retained when the unit is power cycled.

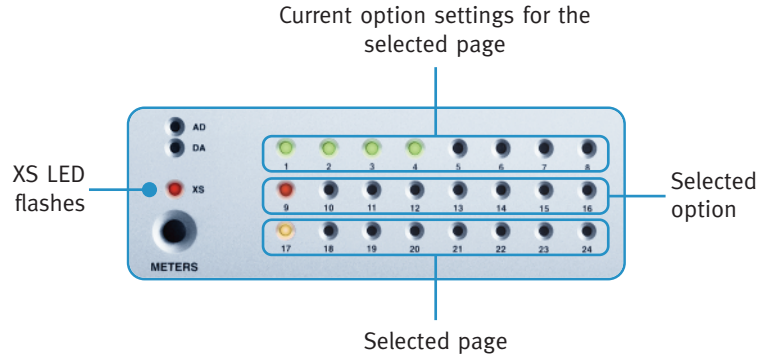

Diagnostic Mode

Holding the **SAMPLE RATE** and **CLOCK** buttons for at least 1.5 seconds when the Alpha-Link unit is switched on will put it into diagnostic mode, indicated by a flashing **XS** LED. Diagnostic mode can be cancelled either by power cycling the unit or by simultaneously pressing both the **SAMPLE RATE** and **CLOCK** buttons once more.

*Any changes will be lost if the unit is power cycled; the internal memory is only written to if diagnostic mode is exited by pressing both **SAMPLE RATE** and **CLOCK** buttons. Please allow time for any changes to take effect.*

Picking a Page of Virtual Switches

Several pages of virtual switches are provided, the current page being indicated in AMBER by the lower row of meter LEDs where the Channel 17 LED indicates Page 1, Channel 18 indicates Page 2 etc. Pressing the **METERS** button will step through the available pages – each Alpha-Link model is different and may provide additional pages.

Selecting an Option

For each page of switches, the middle row of meter LEDs indicates, in RED, the currently selected switch such that Channel 9 LED indicates Switch 1, Channel 10 indicates Switch 2 etc. Pressing the **OUTPUT** button will cycle through all switches for that page.

Setting an Option

The current setting of each option in the current page is indicated, in GREEN, by the state of the corresponding LED in the first row of meter LEDs where the Channel 1 LED indicates the state of Option 1, Channel 2 indicates Option 2 etc. When an option is selected, pressing the **INPUT** button toggles the state of that option (ON or OFF).

Tables detailing the available options and their default settings will be found on the following pages. In each table the relevant LED states are indicated as either extinguished ('○') or illuminated ('●').

Firmware Version

Whilst in diagnostic mode, the Alpha-Link unit can also be set to display the current firmware version by simultaneously pressing both the **SAMPLE RATE** and **CLOCK** buttons. The firmware version will be displayed across the top row of meter LEDs (1 through 8) whilst the buttons are pressed; releasing the buttons will return the unit to normal operation.

The number will be displayed as a two digit binary number where LEDs 1 to 4 indicate the 'major' part and LEDs 5 to 8 the 'minor' part; the table here can be used to convert the numbers displayed on the unit into decimal – for example a version number of '1.2' would display as '○ ○ ○ ● ○ ○ ● ○' (where '●' indicates an illuminated LED).

Current Firmware Versions

At the time of writing, the following firmware versions are valid for each unit:

- Alpha-Link AX V2.4
- Alpha-Link MADI-AX V2.4
- Alpha-Link MADI-SX * V2.9
- Alpha-Link LIVE * V2.10

* Firmware version V2.9 for these units introduced improved locking of AES inputs 9 through 24 and, in association with a hardware modification on the main digital board, enables the unit to additionally lock to video sync. The required hardware modification has been factory fitted to Alpha-Link LIVE serial numbers 0100 upwards and Alpha-Link MADI-SX serial numbers 1201 upwards; earlier units will not lock to video without this modification, a charge will be applied for modifying such units.

| LEDs | Number |
|---------|--------|
| ○ ○ ○ ○ | 0 |
| ○ ○ ○ ● | 1 |
| ○ ○ ● ○ | 2 |
| ○ ○ ● ● | 3 |
| ○ ● ○ ○ | 4 |
| ○ ● ○ ● | 5 |
| ○ ● ● ○ | 6 |
| ○ ● ● ● | 7 |
| ● ○ ○ ○ | 8 |
| ● ○ ○ ● | 9 |
| ● ○ ● ○ | 10 |
| ● ○ ● ● | 11 |
| ● ● ○ ○ | 12 |
| ● ● ○ ● | 13 |
| ● ● ● ○ | 14 |
| ● ● ● ● | 15 |

Virtual Switches, Page One (Alpha-Link AX, MADI-AX and MADI-SX)

Settings in bold indicate defaults. Please also refer to the notes overleaf for details regarding each setting.

| LED | Option | Setting | LED State | See Note |
|-----|---|-------------------------------|----------------------------------|----------|
| 1 | Number of MADI channels (not AX) | 64 (32 at 2Fs) | <input type="radio"/> | 1. |
| | | 56 (28 at 2Fs) | <input checked="" type="radio"/> | |
| 2 | MADI 2Fs data format (not AX) | High Speed | <input type="radio"/> | 2. |
| | | Legacy (SMUX) | <input checked="" type="radio"/> | |
| 3 | ADAT sample rate (AX, MADI-AX) / AES/EBU 2Fs data format (MADI-SX) | Fs / High Speed | <input type="radio"/> | 2. |
| | | 2Fs / Legacy (SMUX) | <input checked="" type="radio"/> | |
| 4 | Analogue/Digital connection mode | Analogue first (lowest) | <input type="radio"/> | 3. |
| | | Digital first (lowest) | <input checked="" type="radio"/> | |
| 5 | ADAT or AES/EBU channel status | Use | <input type="radio"/> | 4. |
| | | Ignore | <input checked="" type="radio"/> | |
| 6 | Sample rate when an Fs rate signal is applied to the wordclock input | Fs | <input type="radio"/> | 5. |
| | | 2Fs | <input checked="" type="radio"/> | |
| 7 | Wordclock output at 2Fs | 2Fs Rate Clock | <input type="radio"/> | 6. |
| | | Fs Rate Clock | <input checked="" type="radio"/> | |
| 8 | Phase angle of Wordclock output | 0° | <input type="radio"/> | 7. |
| | | 90° | <input checked="" type="radio"/> | |

Virtual Switches, Page One (Alpha-Link LIVE)

Settings in bold indicate defaults. Please also refer to the notes opposite for details of each setting.

| LED | Option | Setting | LED State | See Note |
|-----|--|--------------------------------|----------------------------------|----------|
| 1 | Number of MADI channels | 64 (32 at 2Fs) | <input type="radio"/> | 1. |
| | | 56 (28 at 2Fs) | <input checked="" type="radio"/> | |
| 2 | MADI 2Fs data format | High Speed | <input type="radio"/> | 2. |
| | | Legacy (SMUX) | <input checked="" type="radio"/> | |
| 3 | AES/EBU 2Fs data format | High Speed | <input type="radio"/> | 2. |
| | | Legacy (SMUX) | <input checked="" type="radio"/> | |
| 4 | Analogue/Digital connection mode | Analogue first (lowest) | <input type="radio"/> | 3. |
| | | Digital first (lowest) | <input checked="" type="radio"/> | |
| 5 | AES/EBU channel status | Use | <input type="radio"/> | 4. |
| | | Ignore | <input checked="" type="radio"/> | |
| 6 | Sample rate when an Fs rate signal is applied to the wordclock input | Fs | <input type="radio"/> | 5. |
| | | 2Fs | <input checked="" type="radio"/> | |
| 7 | Wordclock output at 2Fs | 2Fs Rate Clock | <input type="radio"/> | 6. |
| | | Fs Rate Clock | <input checked="" type="radio"/> | |
| 8 | Phase angle of Wordclock output | 0° | <input type="radio"/> | 7. |
| | | 90° | <input checked="" type="radio"/> | |

Notes for Virtual Switches, Page One

1. There are two MAD I channel formats; 56 or 64 channel. The 56 channel format allows for $\pm 10\%$ deviation from the nominal sample rate whilst the 64 channel format uses the full capacity of the MAD I stream fixed to the selected sample rate. Not all MAD I interfaces support both formats; please refer to the documentation for the connected interface to determine the correct format to use. Note that the MAD I link transmission rate is always fixed hence at higher or '2Fs' sample rates the channel capacity is halved to either 28 or 32 channels.

For Alpha-Link LIVE to control 8-RMP units, it is essential that the MAD I port be set to operate in 56 channel mode; control signals are transmitted as data packets over channel 57.

2. These options are used either to determine the rate of the master clock or to set the data format for that interface.
 - a. If the unit is set to lock to the interface in question, these options determine how the clock signal embedded in the selected clock source is interpreted *when the clock is below 57kHz (Fs rate)*:
 - When the source sample rate is Fs, the '2Fs / Legacy (SMUX)' setting is invalid; 'Fs / High Speed' must be selected to receive valid data. The distributed clock will be Fs.
 - When the source sample rate is 2Fs – with 'Legacy (SMUX)' format data – the 'Fs / High Speed' setting is invalid; '2Fs / Legacy (SMUX)' must be selected to receive valid data. (For ADAT – AX and MAD I-AX – units it this action that forces the interface to 2Fs.) The distributed clock will be Fs.When Alpha-Link is provided with a 2Fs rate clock (above 57kHz) the setting of this switch will be ignored and the distributed clock will always be 2Fs rate.
 - b. If the unit is *not* set to lock to the interface in question *and the interface provides multiple data formats (ie. not ADAT)*, these options are used to set the 2Fs data format for that interface:
 - When set to 'Legacy (SMUX)' a half-rate frame pattern will be used. This format is functionally compatible with Fs rate interfaces and may be required to interface to older equipment.
 - When set to 'High Speed' a proper 2Fs frame pattern will be used.

3. When both analogue and digital (either ADAT or AES/EBU) input groups are both connected to the Expansion Bus or MAD1 output groups, this option determines which input group feeds the output group first and hence affects the order in which input channels are assigned to channels on the Expansion Bus or the MAD1 stream. Similarly, when the Expansion Bus or MAD1 input groups are routed to both the analogue and ADAT output groups, this switch also determines the order in which the input channels are split across the selected output groups. Please refer to the **Routing Matrix Control** section on page 6 for more detail.
4. Many ADAT and AES/EBU interfaces embed sample rate information in the data stream which Alpha-Link can use to configure itself. This information on occasion however might not correlate with the actual sample rate and in such circumstances Alpha-Link can be set to ignore this information and in doing so Alpha-Link will fall back on the measured clock signals and the High Speed/Legacy (SMUX) switch settings.
5. Further to point 2. opposite, when Alpha-Link is set to lock to external wordclock whilst operating at 2Fs, it may be necessary to inform the unit how to treat the applied clock signal if that signal is at Fs rate.
6. The Wordclock output should normally follow the selected sample rate. When operating at 2Fs rates however it may be necessary for the Wordclock output to run at either Fs or 2Fs rates.
7. At the time of writing, only a fixed 90° angle is actually used so this option has no effect.

Virtual Switches, Page Two (Alpha-Link AX and MADI-AX)

Settings in bold indicate defaults. Please refer to the notes overleaf for details regarding each setting.

| LED | Option | Setting | LED States | See Note |
|-----|---------------------------------------|----------------------|--|----------|
| 1 | ADAT clock source | ADAT In 1 – 8 | <input type="radio"/> <input type="radio"/> | 1. |
| | | ADAT In 9 – 16 | <input checked="" type="radio"/> <input type="radio"/> | |
| | | ADAT In 17 – 24 | <input type="radio"/> <input checked="" type="radio"/> | |
| 3 | Clock source for 'External' selection | Wordclock | <input type="radio"/> | 2. |
| | | MADI (MADI-AX only) | <input checked="" type="radio"/> | |
| 4 | Unused | n/a | n/a | – |
| 5 | Unused | n/a | n/a | – |
| 6 | Unused | n/a | n/a | – |
| 7 | Unused | n/a | n/a | – |
| 8 | Unused | n/a | n/a | – |

Virtual Switches, Page Two (Alpha-Link MADI-SX and LIVE)

Settings in bold indicate defaults. Please also refer to the notes overleaf for details regarding each setting.

| LED | Option | Setting | LED States | See Note |
|--------------------------------|--|----------------------------------|---|----------|
| 1 2 | AES/EBU clock source (port 'A' only) | AES/EBU In 1 & 2 | <input type="radio"/> <input type="radio"/> | 3. |
| | | AES/EBU In 3 & 4 | <input checked="" type="radio"/> <input type="radio"/> | |
| | | AES/EBU In 5 & 6 | <input type="radio"/> <input checked="" type="radio"/> | |
| | | AES/EBU In 7 & 8 | <input checked="" type="radio"/> <input checked="" type="radio"/> | |
| 3 | Clock source for 'External' selection | Wordclock (MADI-SX) | <input type="radio"/> | 4. |
| | | MADI or Video (LIVE) | <input checked="" type="radio"/> | |
| 4 5 | AES/EBU sample rate converters (port 'A' only) | Input 1 & 2 enabled | <input type="radio"/> | 5. |
| | | Input 1 & 2 bypassed | <input checked="" type="radio"/> | |
| Input 3 & 4 enabled | | <input type="radio"/> | | |
| Input 3 & 4 bypassed | | <input checked="" type="radio"/> | | |
| 6 | | Input 5 & 6 enabled | <input type="radio"/> | |
| | | Input 5 & 6 bypassed | <input checked="" type="radio"/> | |
| 7 | | Input 7 & 8 enabled | <input type="radio"/> | |
| | | Input 7 & 8 bypassed | <input checked="" type="radio"/> | |
| 8 | Unused | n/a | n/a | – |

Notes for Virtual Switches, Page Two

1. Because the Alpha-Link AX and MADI-AX units carry three ADAT ports, there are three ports to choose from when selecting an ADAT clock source. To enable one of the three ports to be selected the first two option switches operate together.
2. For Alpha-Link MADI-AX only. When **EXT** is selected as the clock source, this can optionally be MADI instead of a separate Wordclock feed. If MADI is selected here the clock signal embedded in the incoming MADI stream can be used as the clock source.
3. The Alpha-Link MADI-SX and LIVE units can optionally lock to one of the four AES/EBU inputs provided on AES/EBU port 'A'. To enable one of these four inputs to be selected the first two option switches operate together.

For the Alpha-Link unit to lock to one of these inputs requires that the sample rate converter on that input is also bypassed – see point 5. below.

4. For Alpha-Link MADI-SX this option defaults to 'Wordclock' whilst for Alpha-Link LIVE the default is 'MADI or Video'. When the clock source is set for **EXT**, this option allows either MADI or Video to be used as the clock source – either the clock signal embedded in the incoming MADI stream or an external PAL or NTSC video sync signal.

When locking to video it will be necessary to specify the video standard and the unit sample rate using switches 5 through 8 on virtual switches page three.

5. Sample rate conversion is provided on the four AES/EBU inputs on AES/EBU port 'A'. These converters can be switched out in pairs.

Virtual Switches, Page Three (Alpha-Link MADI-SX and LIVE)

Settings in bold indicate defaults. Please also refer to the notes overleaf for details regarding each setting.

| LED | Option | Setting | LED States | See Note | |
|------------------|--|---|--|--|----|
| 1 | Control Host | MADI | <input type="radio"/> | 1. | |
| | | Expansion Bus | <input checked="" type="radio"/> | | |
| 2 | Unused | n/a | n/a | – | |
| 3 | Unused | n/a | n/a | – | |
| 4 | Unused | n/a | n/a | – | |
| 5 | External Clock Source (non-wordclock) | MADI | <input type="radio"/> <input type="radio"/> <input type="radio"/> <input type="radio"/> | 2. | |
| | | NTSC and 44.1kHz | <input checked="" type="radio"/> <input type="radio"/> <input type="radio"/> <input type="radio"/> | 3. | |
| NTSC and 48kHz | | <input type="radio"/> <input checked="" type="radio"/> <input type="radio"/> <input type="radio"/> | | | |
| NTSC and 88.2kHz | | <input checked="" type="radio"/> <input checked="" type="radio"/> <input type="radio"/> <input type="radio"/> | | | |
| 6 | | | NTSC and 96kHz | <input type="radio"/> <input type="radio"/> <input checked="" type="radio"/> <input type="radio"/> | 4. |
| 7 | | | PAL and 44.1kHz | <input checked="" type="radio"/> <input type="radio"/> <input checked="" type="radio"/> <input type="radio"/> | |
| 8 | | | PAL and 48kHz | <input type="radio"/> <input checked="" type="radio"/> <input checked="" type="radio"/> <input type="radio"/> | |
| | | | PAL and 88.2kHz | <input checked="" type="radio"/> <input checked="" type="radio"/> <input checked="" type="radio"/> <input type="radio"/> | |
| | | PAL and 96kHz | <input type="radio"/> <input type="radio"/> <input type="radio"/> <input checked="" type="radio"/> | | |

Notes for Virtual Switches, Page Three

1. The Expansion port on the rear of the Alpha-Link can be used to perform firmware upgrades. The Alpha-Link LIVE unit runs different firmware to the other units in the Alpha-Link range but the Expansion port is unable to detect this difference. Therefore, to guard against accidental and incorrect firmware updates, the Alpha-Link LIVE will by default not accept firmware updates over the Expansion port. At the time of writing, firmware update is not possible over the MADI port.
2. When **EXT** is selected as the clock source and 'MADI or Video' has been selected in virtual switches page two, setting switches 5 through 8 to 'off' will enable the clock signal embedded in the incoming MADI stream to be used as the clock source.
3. When **EXT** is selected as the clock source and 'MADI or Video' has been selected in virtual switches page two, these virtual switches allow Alpha-Link to lock to an applied NTSC/colour (29.97Hz) video sync signal. Because the video sync signal obviously carries no sample rate information, it will be necessary to select the required sample rate using the appropriate switches.
4. When **EXT** is selected as the clock source and 'MADI or Video' has been selected in virtual switches page two, these virtual switches allow Alpha-Link to lock to an applied PAL video sync signal. Because the video sync signal obviously carries no sample rate information, it will be necessary to select the required sample rate using the appropriate switches.

Appendix A – AES/EBU Interface

Inputs with Sample Rate Conversion

The inputs of AES/EBU port A (channels 1 through 8) have sample rate conversion available. These sample rate converters combine a wide input-to-output sampling ratio with outstanding dynamic range and ultra low distortion, resulting in high quality even at a 1:1 conversion (where many SRCs offer their lowest quality). In many instances the converters may be left in-circuit albeit at the expense of increased delay through these inputs. If required, the sample rate converters can be bypassed, in pairs, as described in the **System Settings and Diagnostics** section of this guide.

Input Sample Rate and Auxiliary Data

The input sample rate is not extracted from channel status bits but measured from the selected AES/EBU stereo pair on port A (see page 19). Information about ‘Legacy’ or ‘High Speed’ mode may be extracted from the channel status bits if the in-coming stream contains this information but this should not be relied upon (see pages 14 through 17).

Inputs without Sample Rate Conversion

The inputs of AES/EBU ports B and C (channels 9 through 24) do not have sample rate converters. Any signals applied to these inputs (and port A if the sample rate converters are bypassed) must be synchronized to the system.

Output Auxiliary Data

The following will be set in the auxiliary data fields of all AES/EBU output streams:

| | |
|---------------------|--|
| Channel Status Data | Indication of the selected sample rate and mode (‘Legacy’ or ‘High Speed’) All other channel status fields default to ‘1’ |
| User Data Bit | Always set low (‘0’) |
| Validity bit | Always set true (valid) |
| Parity Bit | Always recalculated |

Appendix B – Troubleshooting

| Symptom | Possible Solution |
|---|---|
| There is no sound, all the LEDs are off. | Check that the Alpha-Link unit is connected to the mains supply and that the Power switch is in the 'ON' position. Check the condition of the mains cable. |
| There is no sound. The ADAT, AES/EBU or External Clock indicator LED flashes. The Sample Rate LEDs are off. | Check that the device connected to the WordClock, MADI, ADAT or AES/EBU port is set to transmit a suitable Master Clock signal and operates at a supported sample rate. |
| The Input and Output buttons do not work. The Input and Output LEDs are off. The Clock button does not work. The Sample Rate button does not work. | Is the Alpha-Link unit being used together with a Mixpander card? If so, it is normal for these controls to be deactivated. Otherwise, please contact Solid State Logic's technical support. |
| When the Soundscape Mixer software is started, a dialogue box states that the Alpha-Link firmware is not compatible. | The Alpha-Link firmware needs to be updated. Firmware updates require that the Alpha-Link be connected to an SSL or Soundscape Mixpander card. If in doubt, please contact Solid State Logic's technical support. |
| The sound is distorted. | Use the front panel metering section to check the level of the audio signals. |
| There is no sound. The External Clock indicator LED flashes and the Sample Rate LEDs are off (MADI-SX and LIVE only). | Video Lock is selected as a lock source but the required hardware modification has not been applied. Please contact Solid State Logic's technical support for assistance. |

Support FAQs

To access the latest support information on Alpha-Link, please visit our online support site:

www.solidstatelogic.com/support

The information that you will find there is kept up to date by our support staff to make sure all information is accurate. All information is available to you 24 hours a day, 7 days a week.

If you can't find an answer or solution to your issue, you can submit a question on the site to our support staff for resolution.



Solid State Logic
SOUND || VISION

Support

FAQs, documentation and other useful utilities

A great product is only the start of what sets SSL apart from the rest. We believe that this is why our products demand the best support. To provide this, SSL has a network of sales and service centres throughout the world, including its head office in New York, Los Angeles, Paris and Milan. Through these offices, and specialist distributors in other countries, a full program of backup and technical support is guaranteed. Through this, all of our customers in the global market can be assured of the best service available from SSL's service centres at the company headquarters near Oxford, England.

- Console Resources**
 - Duality
 - AWS 900+
 - C100 HD
 - C200 HD
 - C300 HD
 - SL 8000 X
- Duende**
 - Duende Classic
 - Duende Mini
 - Duende PCIe
 - Plug-ins
- Audio I/O**
 - Alpha-Link Range
 - Delta-Link MADI-HD
 - MadiXtreme
 - MADI Opti-Coax
- Workstation Products**
 - Pro-Convert
 - Mixpander
 - X-ISM Plug-in
 - LMC-1 Plug-in
 - Soundscape
- Analogue Outboard**
 - X-Rack
 - G Series Bus Comp
 - E-Signature Channel
 - SuperAnalogue Ch
 - Hi-Resolution Comp
 - Alpha Channel

Solid State Logic
SOUND || VISION

Appendix C – Alpha-Link Model Numbers

Alpha-Link is available in a variety of configurations. The following table correlates the major differences between the different models with the unit part numbers to aid identification of units:

| Model | SSL Part Number ¹ | Unit Identifier ² | Analogue I/O Level ³ | Digital Interfaces |
|---------|------------------------------|------------------------------|---------------------------------|--------------------|
| AX | 726903X1 | AFN-047 | +22dBu | ADAT |
| MADI-AX | 726902X1 | AFN-046 | +22dBu | ADAT, MADI |
| MADI-SX | 726901X1 | AFN-045 | +22dBu | AES/EBU, MADI |
| LIVE | 726908X1 | AFN-052 | +24dBu | AES/EBU, MADI |
| | 726910X1 | AFN-054 | +18dBu | |

1. This is the SSL Part number for ordering and unit returns
2. This is the number found on the rear of the unit, adjacent to the unit Serial Number
3. Nominal maximum analogue I/O level for odB FS

Solid State Logic

S O U N D | | V I S I O N

Visit SSL at: www.solidstatellogic.com

82BSAM01C

© Solid State Logic

All Rights reserved under International and Pan-American Copyright Conventions

C10 HD, Mixpander, SSL, Solid State Logic, XLogic, XLogic Alpha-Link and **XLogic Alpha-Link 8-RMP** are trademarks of Solid State Logic

All other product names and trademarks are the property of their respective owners and are hereby acknowledged

No part of this publication may be reproduced in any form or by any means, whether mechanical or electronic, without the written permission of Solid State Logic, Oxford, OX5 1RU, England

As research and development is a continual process, Solid State Logic reserves the right to change the features and specifications described herein without notice or obligation.

Solid State Logic cannot be held responsible for any loss or damage arising directly or indirectly from any error or omission in this manual.

E&OE