



Centraverse Boundary Microphone

The Shure Centraverse CVB is a professional boundary electret condenser microphone for use in desktop installed sound reinforcement applications. Available in cardioid and omnidirectional polar patterns and black or white color options, its low-profile design fits seamlessly within any design aesthetic.

Features

- Superior Shure design and rugged, dependable construction
- Available in cardioid or omnidirectional polar patterns
- Attached 12 ft XLR cable
- Mounting holes for secure installation
- CommsShield® technology guards against unwanted RF interference from portable wireless devices (smartphones, etc.)

Model Variations

CVB-B/C: Black, Cardioid

CVB-B/O: Black, Omnidirectional

CVB-W/C: White, Cardioid

CVB-W/O: White, Omnidirectional

Note: Model availability depends on region. See your local Shure dealer or distributor for details.

Installation

1. Install two screws into the mounting surface, exactly 24 mm (15/16 in.) apart. Leave a 5 mm (3/16 in.) gap between the screw head and the mounting surface. Only use screws with a flat-bottom head.
2. Place the microphone onto the screws and slide backwards to lock into place.
3. Connect the XLR cable to a mixer or P.A. system.

Note: This microphone requires +48V phantom power to operate.

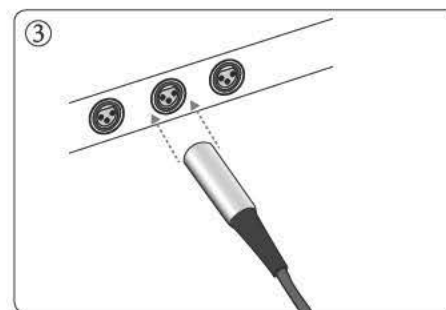
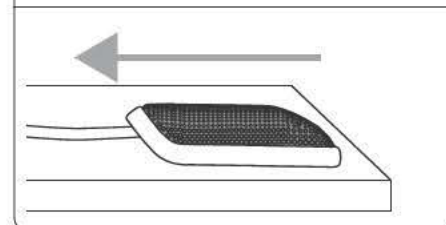
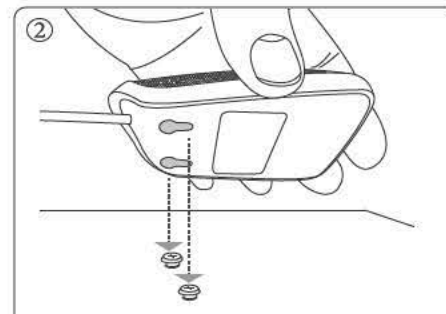
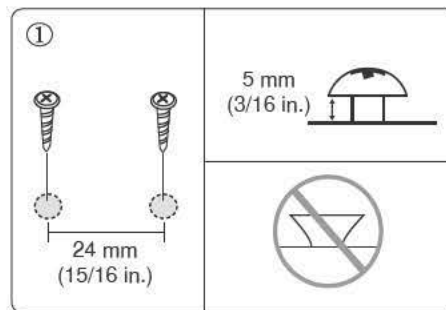

Microphone Placement

Use the following information to achieve the best results for each model variation.

① Cardioid

The cardioid model captures sound in front of the microphone and rejects off-axis sounds. It is best suited to capture one person or a small group in close proximity to one another.

② Omnidirectional

The omnidirectional model captures sound from all angles. It is ideal for capturing larger groups and sounds coming from multiple directions.

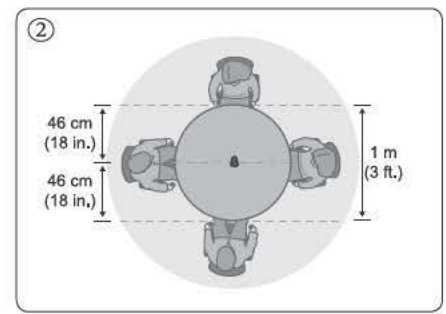
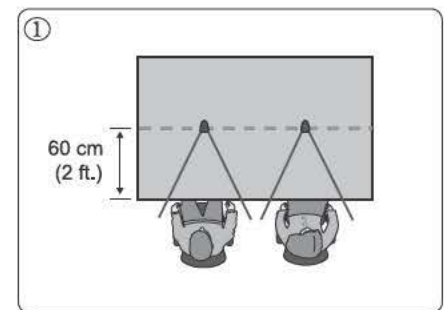

CVB / C

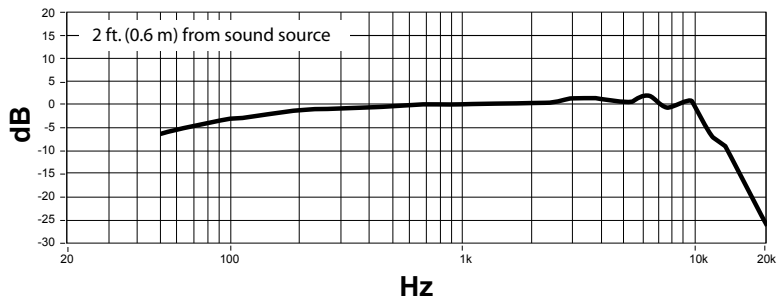
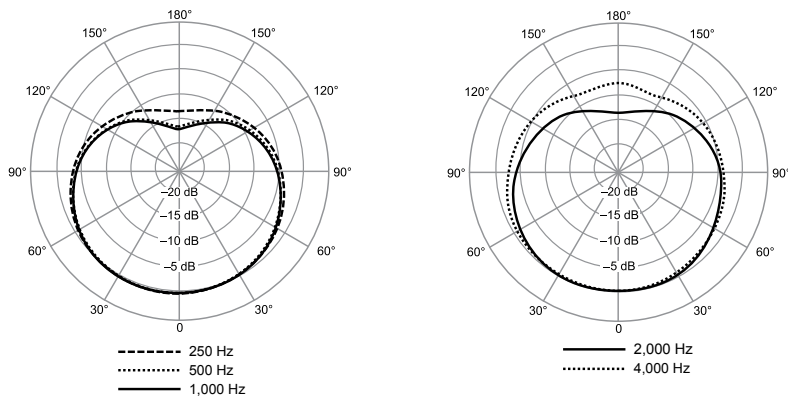

CVB / O

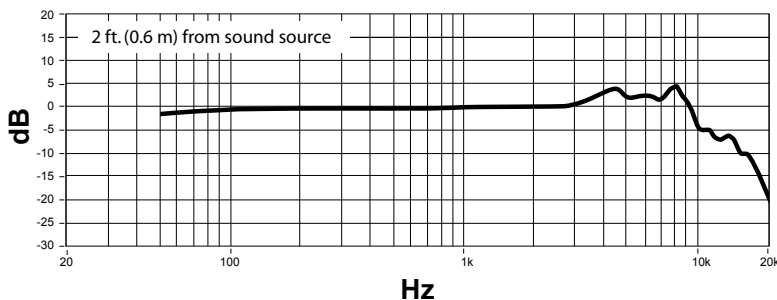
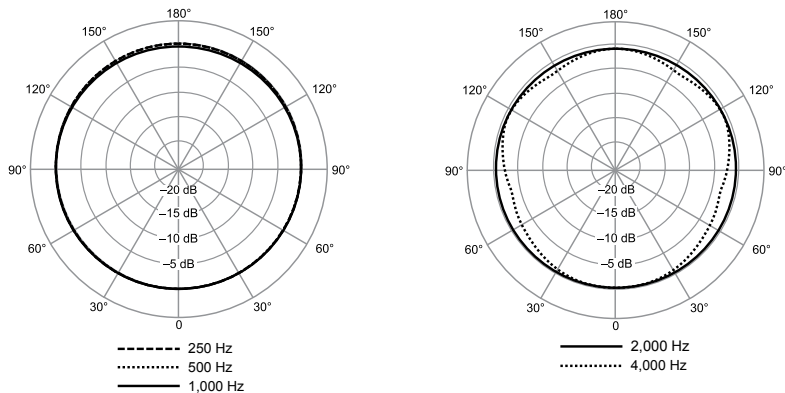

Specifications

Cartridge Type

Electret Condenser

Polar Pattern

CVB/O	Omnidirectional
CVB/C	Cardioid

Frequency Response

70–16000 Hz

Output Impedance

180 Ω

Sensitivity

open circuit voltage, @ 1 kHz, typical

CVB/O	-28 dBV/Pa[1] (40 mV)
CVB/C	-32.5 dBV/Pa[1] (23 mV)

Maximum SPL[2]

1 kHz at 1% THD

CVB/O	117 dB SPL
CVB/C	120 dB SPL

Signal-to-Noise Ratio[3]

Ref. 94 dB SPL at 1 kHz

CVB/O	74 dB
CVB/C	67 dB

Dynamic Range

CVB/O	97 dB
CVB/C	93 dB

Self Noise

equivalent SPL, A-weighted, typical

CVB/O	20 dB SPL
CVB/C	27 dB SPL

Preamplifier Output Clipping Level

@ 1 kHz, at 1% THD

CVB/O	-6 dBV
CVB/C	-7 dBV

Common Mode Rejection

10 Hz to 100 kHz

>45 dB

Polarity

Positive pressure on diaphragm produces positive voltage on pin 2 with respect to pin 3

Environmental Conditions

Operating Temperature	-18 to 57°C (0 to 135°F)
Storage Temperature	-29 to 74°C (-20 to 165°F)
Relative Humidity	0 to 95%

Power Requirements

11–52 V DC[4], 2.0 mA

Weight

8 oz. (227 g)

[1] 1 Pa=94 dB SPL

[2] THD of microphone preamplifier when applied input signal level is equivalent to cartridge output at specified SPL

[3] S/N ratio is the difference between 94 dB SPL and equivalent SPL of self noise, A-weighted

[4] All specifications measured with a 48 Vdc phantom power supply. The microphone operates at lower voltages, but with slightly decreased headroom and sensitivity.

Certifications

Meets essential requirements of all applicable European Directives.

Eligible for CE marking.

The CE Declaration of Conformity can be obtained from Shure Incorporated or any of its European representatives. For contact information please visit www.shure.com

The CE Declaration of Conformity can be obtained from: www.shure.com/europe/compliance

Authorized European representative:

Shure Europe GmbH

Headquarters Europe, Middle East & Africa

Department: EMEA Approval

Jakob-Dieffenbacher-Str. 12

75031 Eppingen, Germany

Phone: 49-7262-92 49 0

Fax: 49-7262-92 49 11 4

Email: EMEAsupport@shure.de

SHURE®

SHURE Incorporated <http://www.shure.com>

United States, Canada, Latin America, Caribbean:

5800 W. Touhy Avenue, Niles, IL 60714-4608, U.S.A.

Phone: 847-600-2000 U.S. Fax: 847-600-1212 Int'l Fax: 847-600-6446

Europe, Middle East, Africa:

Shure Europe GmbH, Phone: 49-7262-92490 Fax: 49-7262-9249114

Asia, Pacific:

Shure Asia Limited, Phone: 852-2893-4290 Fax: 852-2893-4055