

## User's Guide



# M-32 AD

## M-16 AD

The Professional's Converter Solution

**TotalRemote™**

**MADI I/O**

**ADAT™ I/O**

**SteadyClock™**

**SyncCheck®**

Professional 32/16-Channel A/D Converter  
Fully Symmetrical Circuit Design  
Analog Limiter  
32/16-Channel Analog to MADI / ADAT Interface  
24 Bit / 192 kHz Digital Audio  
MIDI Remote Control



AES-10

24 Bit Interface

---

▶	<b>Important Safety Instructions</b> .....	4
---	--	---

▶ **General**

<b>1</b>	<b>Introduction</b> .....	6
<b>2</b>	<b>Package Contents</b> .....	6
<b>3</b>	<b>Brief Description and Characteristics</b> .....	6
<b>4</b>	<b>First Usage – Quick Start</b>	
4.1	Controls - Connectors - Displays .....	7
4.2	Quick Start .....	9
<b>5</b>	<b>Accessories</b> .....	10
<b>6</b>	<b>Warranty</b> .....	11
<b>7</b>	<b>Appendix</b> .....	11

▶ **Usage and Operation**

<b>8</b>	<b>Front Panel Controls</b>	
8.1	Analog Input .....	14
8.2	MADI Out .....	14
8.3	MADI Input .....	14
8.4	MADI Output .....	14
8.5	Limiter.....	15
8.6	Clock Section .....	15
8.7	Meter .....	17
8.8	Remote.....	17
8.9	Lock Keys.....	17
<b>9</b>	<b>Remote Control</b>	
9.1	MIDI.....	18
9.2	MIDI over MADI.....	18
9.3	Remote Control Software.....	19

▶ **Inputs and Outputs**

<b>10</b>	<b>Analog Inputs</b> .....	22
<b>11</b>	<b>Digital Inputs / Outputs</b>	
11.1	ADAT Optical .....	23
11.2	MADI Input .....	23
11.3	MADI Output .....	24
<b>12</b>	<b>Word Clock</b>	
12.1	Wordclock Input and Output .....	25
12.2	Technical Description and Background .....	26
12.3	Cables and Termination.....	27
<b>14</b>	<b>MIDI</b> .....	27

---

▶ **Technical Reference**

<b>15</b>	<b>Technical Specifications</b>	
15.1	Analog .....	30
15.2	Digital Inputs .....	30
15.3	Digital Outputs .....	31
15.4	Digital .....	31
15.5	MIDI .....	32
15.6	General .....	32
15.7	Firmware .....	32
15.8	MADI User Bit Chart .....	32
15.9	Connector Pinouts .....	33
<b>16</b>	<b>Technical Background</b>	
16.1	Terminology .....	34
16.2	Lock and SyncCheck .....	35
16.3	Latency and Monitoring .....	36
16.4	DS – Double Speed .....	37
16.5	QS – Quad Speed .....	37
16.6	MADI Basics .....	38
16.7	SteadyClock .....	39
<b>17</b>	<b>Block Diagram M-32 AD</b> .....	40
<b>18</b>	<b>Block Diagram M-16 AD</b> .....	41
<b>19</b>	<b>MIDI Implementation M-Series</b>	
19.1	Basic SysEx Format .....	42
19.2	Message Types .....	42
19.3	Table .....	43

▶ **Application Examples**

20.1	Formats and Number of Channels .....	48
20.2	Multichannel Playback .....	49
20.3	Multichannel Recording .....	51
20.4	Multichannel Recording and Playback .....	53
20.5	Digital Multicore .....	56
20.6	Multiple Playbacks .....	57

---

## Important Safety Instructions



### **ATTENTION! Do not open chassis – risk of electric shock**

The unit has non-isolated live parts inside. No user serviceable parts inside. Refer service to qualified service personnel.



### **Mains**

- The device must be earthed – never use it without proper grounding
- Do not use defective power cords
- Operation of the device is limited to the manual
- Use same type of fuse only



To reduce the risk of fire or electric shock do not expose this device to rain or moisture. Prevent moisture and water from entering the device. Never leave a pot with liquid on top of the device. Do not use this product near water, i. e. swimming pool, bathtub or wet basement. Danger of condensation inside – don't turn on before the device has reached room temperature.



### **Installation**

Surface may become hot during operation – ensure sufficient ventilation. Avoid direct sun light and do not place it near other sources of heat, like radiators or stoves. When mounting in a rack, leave some space between this device and others for ventilation.



Unauthorized servicing/repair voids warranty. Only use accessories specified by the manufacturer.



Read the manual completely. It includes all information necessary to use and operate this device.

---

## User's Guide



# **M-32 AD**

## **M-16 AD**

### ▶ **General**

---

## 1. Introduction

RME's M-32 AD and M-16 AD are AD-converters with a truly unique feature set. They combine excellent analog circuit design with the latest generation of outstanding low latency AD converter chips. Along with the integrated SteadyClock, they offer AD-conversion of the highest quality.

When developing these units we used all our experience, and also the experience of our customers, to create a unique, excellent and high-quality unit. Although the M-32 AD / M-16 AD are built to highest reference standards, they still offer the typical, outstanding price/performance ratio known from RME.

M-32 AD and M-16 AD are nearly identical. The M-16 has only 16 channels (M-32 = 32 channels) and therefore needs no fan. For reasons of simpler reading this manual will mostly be referenced to the M-32 AD only.

## 2. Package Contents

Please check that the package contains each of the following:

- M-32 AD or M-16 AD
- Power cord
- Manual
- RME Driver CD
- 1 optical cable (TOSLINK), 2 m (6.6 ft)

## 3. Brief Description and Characteristics

The M-32 AD is a 32-channel hi-end AD-converter in reference quality, fully remote controllable. In a standard 19" box with 2 unit height the device offers numerous extraordinary features like Intelligent Clock Control (ICC), SyncCheck<sup>®</sup>, SteadyClock, analog Limiter, three hardware reference levels up to +24 dBu, MAD I/O, ADAT I/O, 192 kHz sample rate, MIDI remote control via MIDI and MAD I, and a digital thru-mode for simplified cascading.

- 32-channel AD-converter, fully symmetrical design
- 4 x ADAT Out, 16 channels @ 96 kHz
- 1 x ADAT In as clock reference
- MAD I/O with thru-mode for unused channels
- Word clock input and output
- MIDI I/O
- Analog Limiter
- 32-channel level meter with 5 LEDs per channel
- Fully remote controllable via MIDI and MAD I
- Overdimensioned power supply
- Temperature controlled low noise fan

---

## 4. First Usage – Quick Start

### 4.1 Controls - Connectors - Displays

The front of the M-32 AD features 32 LED level meters, eleven select keys, and 29 LEDs providing a detailed status display.

The analog input sensitivity can be changed in the area **ANALOG INPUT** by the select key.

**M-32 AD:** The key **MADI OUT** routes the converted input signal to channels 1 to 32 or 33 to 64 of the MADI output signal.

**M-16 AD:** The key **MADI OUT** routes the converted input signal to channels 1 to 16, 17 to 32, 33 to 48 or 49 to 64 of the MADI output signal.

The MADI input signal for pass-through and cascading units can be optical or coaxial. The key **INPUT** switches the source. **STATE** displays the current status of the input signal (Lock / Sync, 56- / 64-channel mode, 48K Frame / 96K Frame format).

The MADI output signal is configured in the **MADI OUTPUT** section. The key **FRAME** changes between 48K and 96K Frame, the key **FORMAT** between 56-channel and 64-channel mode.

When activated the 32-channel analog **LIMITER** prevents input overloads and also audible distortion.

The 32 level meter of the **ANALOG INPUT LEVEL DISPLAY** show the input level per channel as digital value (dBFS). When the Limiter has been activated, its interaction is signalled by a blue LED per channel.

In the **CLOCK SECTION** the current clock reference and frequency multiplier is chosen.

**METER PH** provides a Peak Hold function, either permanently (**ON**) or switched off by Auto Reset (**AR**) after 3 seconds.

**REMOTE** defines the source for MIDI remote control operation: MADI or 5-pin DIN jack.

**MIDI INPUT** indicates received MIDI data from the 5-pin DIN input or the MADI input.

**LOCK KEYS** deactivates all keys. This way the M-32 AD is secured against accidental operating errors.

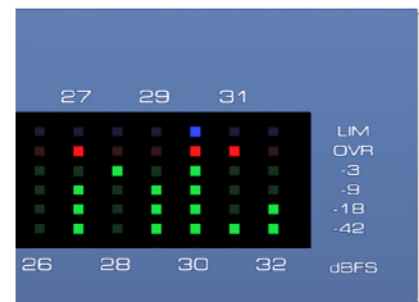

---

The rear panel of the M-32 AD has 32 analog inputs, mains power, MIDI I/O, word clock I/O, MADI I/O and ADAT I/O.

**ANALOG INPUTS:** 32 balanced line inputs via 1/4" TRS inputs and four 25-pin D-sub connectors.

**WORD IN (BNC):** A push switch allows for an internal termination to be activated (75 Ohms).

**WORD OUT (BNC):** Standard word clock output.

**ADAT SYNC IN (TOSLINK):** Standard ADAT optical port for clock synchronization.

**ADAT OUTPUTS 1 to 4 (TOSLINK):** Standard ADAT optical ports.

**MADI I/O optical:** Standard MADI ports.

**MADI I/O coaxial (BNC):** Standard MADI ports.

**MIDI I/O (5-pin DIN):** MIDI input and output via 5-pin DIN jacks. Used to remote control the M-32 AD, and to transmit MIDI data via MADI.



**IEC receptacle** for power connection. The specially developed, internal hi-performance switch mode power supply lets the M-series operate in the range of 100V to 240V AC. It is short-circuit-proof, has an integrated line-filter, is fully regulated against voltage fluctuations, and suppresses mains interference.



---

## 4.2 Quick Start

After connection of all cables and power-on of the device, the configuration of the M-32 AD starts in the CLOCK section. Choose a clock source and a sample rate.

Connect the TRS-jacks or the D-sub connector with the analog signal source. Change the input sensitivity by pressing ANALOG INPUT until the input level is sufficient to avoid noisy operation. Try to achieve an optimum input level by adjusting the source itself. Raise the source's output level until the red OVR LEDs flash at the loudest parts of the signal, then reduce the level a bit until no more Overs are detected.

The analog line inputs of the M-32 AD can be accessed by using D-sub (with an optional XLR multicore) and 1/4" TRS jacks. Both are internally connected, so not operational at the same time. The electronic input stage is built in a servo balanced design which handles unbalanced (mono TS) and balanced (XLR, stereo TRS jacks) correctly, automatically adjusting the level reference.

When switched on for the first time the M-32 AD starts in a default mode which should be suitable for most applications:

- AD conversion in master mode (CLOCK INTERNAL)
- Sample rate 44.1 kHz
- Level reference +19 dBu

The M-32 AD stores all current settings and automatically activates them when the device is turned on.

---

## 5. Accessories

RME offers several optional components for the M-32 AD:

<b>Part Number</b>	<b>Description</b>
OK0050	Optical cable, Toslink, 0.5 m (1.7 ft)
OK0100	Optical cable, Toslink, 1 m (3.3 ft)
OK0200	Optical cable, Toslink, 2 m (6.6 ft)
OK0300	Optical cable, Toslink, 3 m (9.9 ft)
OK0500	Optical cable, Toslink, 5 m (16.4 ft)
OK1000	Optical cable, Toslink, 10 m (32.8 ft)
BO25MXLR8F3	Analog Breakout Cable 25-pin D-sub to 8 x XLR female, 3 m (9.9 ft)
BO25MXLR8F6	same, 6 m (19.8 ft)
BO25MXLR8F10	same, 10 m (33 ft)
MADI Optical Cable:	
ONK0100	MADI Optical Network Cable, 1 m (3.3 ft)
ONKD0300	MADI Optical Network Cable, 3 m (9.9 ft)
ONKD0600	MADI Optical Network Cable, 6 m (19.8 ft)
ONKD1000	MADI Optical Network Cable, 10 m (32.8 ft)
ONKD2000	MADI Optical Network Cable, 20 m (65.6 ft)
ONKD5000	MADI Optical Network Cable, 50 m (164 ft)

---

## 6. Warranty

Each individual M-32 AD / M-16 AD undergoes comprehensive quality control and a complete test at IMM before shipping. The usage of high grade components allows us to offer a full two year warranty. We accept a copy of the sales receipt as valid warranty legitimation.

If you suspect that your product is faulty, please contact your local retailer. The warranty does not cover damage caused by improper installation or maltreatment - replacement or repair in such cases can only be carried out at the owner's expense.

Audio AG does not accept claims for damages of any kind, especially consequential damage. Liability is limited to the value of the Fireface UC. The general terms of business drawn up by Audio AG apply at all times.

## 7. Appendix

RME news and further information can be found on our website:

<http://www.rme-audio.com>

Distributor: Audio AG, Am Pfanderling 60, D-85778 Haimhausen, Tel.: (49) 08133 / 918-70

Manufacturer:  
IMM Elektronik GmbH, Leipziger Strasse 32, D-09648 Mittweida

### Trademarks

All trademarks and registered trademarks belong to their respective owners. RME, Hammerfall and DIGICheck are registered trademarks of RME Intelligent Audio Solutions. SteadyClock, SyncAlign, SyncCheck, ZLM, M-32 AD and M-16 AD are trademarks of RME Intelligent Audio Solutions. Alesis and ADAT are registered trademarks of Alesis Corp. ADAT optical is a trademark of Alesis Corp. S/MUX is copyright Sonorus. Microsoft, Windows, 2000/XP/Vista/7 are trademarks or registered trademarks of Microsoft Corp.

Copyright © Matthias Carstens, 04/2010. Version 1.2

All entries in this User's Guide have been thoroughly checked, however no guarantee for correctness can be given. RME cannot be held responsible for any misleading or incorrect information provided throughout this manual. Lending or copying any part or the complete manual or its contents as well as the software belonging to it is only possible with the written permission from RME. RME reserves the right to change specifications at any time without notice.

---

## CE / FCC Compliance

### CE

This device has been tested and found to comply with the limits of the European Council Directive on the approximation of the laws of the member states relating to electromagnetic compatibility according to RL2004/108/EG, and European Low Voltage Directive RL2006/95/EG.

### FCC

This equipment has been tested and found to comply with the limits for a Class B digital device, pursuant to Part 15 of the FCC Rules. These limits are designed to provide reasonable protection against harmful interference in a residential installation. This equipment generates, uses, and can radiate radio frequency energy and, if not installed and used in accordance with the instructions, may cause harmful interference to radio communications. However, there is no guarantee that interference will not occur in a particular installation. If this equipment does cause harmful interference to radio or television reception, which can be determined by turning the equipment off and on, the user is encouraged to try to correct the interference by one or more of the following measures:

- Reorient or relocate the receiving antenna.
- Increase the separation between the equipment and receiver.
- Connect the equipment into an outlet on a circuit different from that to which the receiver is connected.
- Consult the dealer or an experienced radio/TV technician for help.

### RoHS

This product has been soldered lead-free and fulfils the requirements of the RoHS directive.

### ISO 9001

This product has been manufactured under ISO 9001 quality management. The manufacturer, IMM Elektronik GmbH, is also certified for ISO 14001 (Environment) and ISO 13485 (medical devices).

## Note on Disposal

According to the guide line RL2002/96/EG (WEEE – Directive on Waste Electrical and Electronic Equipment), valid for all european countries, this product has to be recycled at the end of its lifetime.

In case a disposal of electronic waste is not possible, the recycling can also be done by IMM Elektronik GmbH, the manufacturer of the M-32 AD / M-16 AD.



For this the device has to be sent **free to the door** to:

IMM Elektronik GmbH  
Leipziger Straße 32  
D-09648 Mittweida  
Germany

Shipments not prepaid will be rejected and returned on the original sender's costs.

---

## User's Guide



# **M-32 AD**

## **M-16 AD**

### ▶ Usage and Operation

## 8. Front Panel Controls

### 8.1 Analog Input

In the **INPUT** area, the select key causes a change of the analog input sensitivity, referenced to digital full scale level (0 dBFS) of the AD-converters. The choices are: **+13 dBu**, **+19 dBu** and **+24 dBu**.

As the adaptation is performed in the analog domain, the M-32 AD achieves the highest possible values for Signal to Noise ratio and distortion in any setting.



### 8.2 MADI Out

**M-32 AD:** The key **MADI OUT** routes the converted input signal to channels 1 to 32 or 33 to 64 of the MADI output signal.

**M-16 AD:** The key **MADI OUT** routes the converted input signal to channels 1 to 16, 17 to 32, 33 to 48 or 49 to 64 of the MADI output signal.



### 8.3 MADI Input

The key **INPUT** sets the input to optical or coaxial.

The STATE display helps to avoid errors, and makes handling the digital MADI format easier.

The SYNC LED lights up as soon as a valid signal is present at the input. An un-synchronous input signal will be signalled by flashing of the SYNC LED.

64-channel and 96k frame format are displayed by one LED each. With those LEDs off, the input signal is 56-channel and 48k frame format.

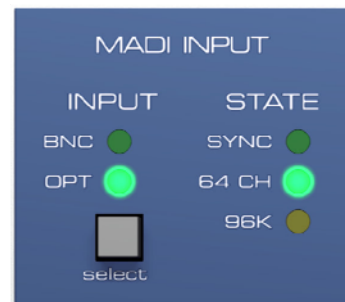

### 8.4 MADI Output

The keys **FRAME** and **FORMAT** configure the MADI output signal as follows:

**FRAME:** 48k or 96k frame. 48k frame can be used with Single, Double and Quad Speed. 96k frame is limited to the range 64 kHz to 96 kHz (Double Speed).

**FORMAT:** 56-channel or 64-channel format.

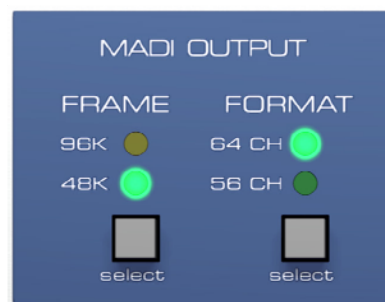

---

## 8.5 Limiter

For the reference converter ADI-8 QS, RME developed a new fully symmetrical circuit design with digitally controlled release time. The same circuit has been added to the M-32 AD. While the analog limiter is constantly within the signal path, it operates fully transparent as long as there is no control signal generated, so does not cause noise or distortion. This special feature made it possible to define a threshold of +3 dB in deactivated mode, preventing an overload of more than 3 dB of the AD-converters. This avoids not only extreme overload effects, but also prevents the AD-converters from being damaged.

Both the fully symmetrical design and the digitally controlled release time contribute to the reduction of the unavoidable distortion of a peak limiter (linearity errors of the control elements, generation of the control voltage). The distortion value of about 0.3% stays the same at any level and any frequency.

Another exceptional feature is the ability to handle extremely high levels. At the level references +24 dBu, +19 dBu and +13 dBu up to +30 dBu can be fed, the signal is still limited correctly (-3 dBFS), THD is still 0.3%. At the setting +4.2 dBu the maximum unclipped input level is +24 dBu. So there is more than 20 dB overload possible!



Note: As with all such basic designs, increasing dynamic ratio and gain reduction causes audible pumping effects.

## 8.6 Clock Section

The source and frequency of the unit's clock is configured in the CLOCK SECTION. The key CLOCK lets you step through the options external clock (Word, MADI, ADAT) and internal clock (44.1 kHz or 48 kHz). The button STATE sets internal, but also the external sample rate to double or quadruple of the basic sample rate.

### WCK, MADI, ADAT (Slave Mode)

Sets the corresponding input to work as clock reference. A missing or invalid clock source signal is indicated by flashing of the corresponding LED.

### 44.1, 48 (Master Mode)

Activates the internal clock with a sample rate of 44.1 kHz or 48 kHz.

### DS, QS

With the DS LED additionally lit, the sample rate will be 88.2 or 96 kHz, with QS lit it will be 176.4 or 192 kHz.

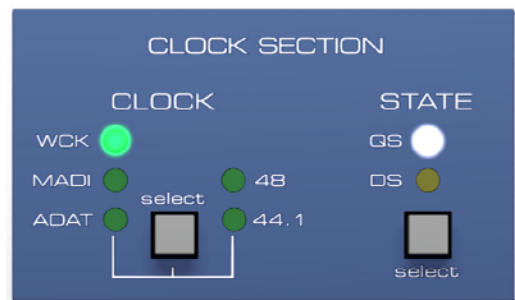

A selection of DS and QS is also possible when using external clock (Slave). If the M-32 AD should operate at 192 kHz, but receives a synchronous word clock of 48 kHz, the button STATE activates DS or QS mode. This way, AD-conversion and digital outputs are configured to operate in the frequency ranges Single Speed, Double Speed or Quad Speed.



*In internal clock mode it is mandatory that the clock rate of the source is synchronous to the M-32 AD. Therefore the external device has to be synchronized by the M-32 AD's word clock output or ADAT/MADI output.*

The M-32 AD thus has to be master, all devices connected to it have to be in slave mode. In order to avoid clicks and drop outs due to faulty or missing synchronicity, a special process called *SyncCheck* compares the incoming data and the M-32 AD's internal clock. The SYNC state is indicated by a flashing (error) or constantly lit (OK) LED.

The key **STATE** is used to configure the M-32 AD, and with this all of its outputs, to the frequency ranges Single Speed, Double Speed or Quad Speed.

#### **No LED (Single Speed)**

All outputs carry a signal in the range of 32 kHz up to 48 kHz.

#### **DS (Double Speed)**

64 kHz up to 96 kHz. ADAT and MADI stay at no higher than 48 kHz, with the data transmitted in the S/MUX format. Therefore ADAT is limited to 16 channels (4 per optical output) in this mode. In case MADI OUTPUT has been set to 96k frame, the MADI output also uses 96 kHz, but is still limited to 32 channels.

#### **QS (Quad Speed)**

176.4 kHz up to 192 kHz. MADI stays at no higher than 48 kHz, with the data transmitted in the S/MUX4 format. Therefore ADAT is limited to 8 channels (2 per optical output) in this mode. MADI is limited to 16 channels.

#### **Follow Clock**

Follow Clock automatically configures the Clock State, setting the unit into Single Speed, Double Speed or Quad Speed operation.

Activation: during display of the firmware version press the CLOCK STATE button. Both LEDs DS/QS light up. Deactivation: same, both LEDs stay dark.

**Word:** In Follow Clock mode the M-32 AD follows the word input clock automatically over all three ranges. So at 96 kHz the DS LED automatically lights up, at 192 kHz the QS LED. A manual configuration via the STATE button is not required.

**MADI:** The format 48 kHz Frame does not allow for a detection of the current sample rate range, therefore an activated Follow Clock will have no effect. A change to Double Speed is performed when MADI is present in 96 kHz Frame format, then a manual configuration via the STATE button is not required. Additionally the unit remembers the MADI OUTPUT FRAME 96K setting, and activates it again when 96k Frame is found at the input.

**ADAT:** A change to Double Speed is performed when the ADAT Signal includes the Double Speed flag. Then a manual configuration via the STATE button is not required. A Quad Speed flag does not exist, so no change will be performed automatically. In case the clock source sends the DS flag even at Single Speed, Follow Clock has to be deactivated.



---

### Word Clock Out

The word clock output can follow the current sample rate up to 192 kHz (*Follow Sample Rate*), or stay in the Single Speed range (*Always Single Speed*). The latter is default. These options can only be changed by MIDI Remote, they can not be set directly at the unit.

Note: A reliable sample-accurate synchronicity between multiple devices having digital interfaces in S/MUX technology (ADAT and MADI) at sample rates in the Double Speed and Quad Speed range is only possible when all units are synced by Single Speed word clock. Because of the S/MUX method the device else can not know which of the incoming 2 (DS) or 4 (QS) word clock edges is the right one.

### 8.7 Meter

**METER PH** provides a Peak Hold function for all level meters, either permanently (**ON**) or switched off by Auto Reset (**AR**) after 3 seconds.

In mode ON, a reset (erasing the current peak values) is issued by a single push of the PH button. The function itself is not changed.

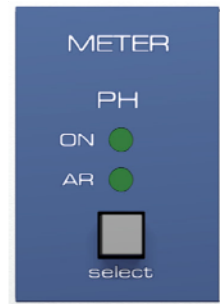

### 8.8 Remote

REMOTE defines the source of MIDI remote control commands. Choices are the MIDI DIN jack and the MADI input.

Note: Via MIDI remote control, all front panel controls can be locked (Lock Keys). An exception is the LOCK KEYS key itself. Therefore a locking of all the controls can be revoked directly at the unit at any time.



### 8.9 Lock Keys

**LOCK KEYS** deactivates all keys. This way the M-32 AD is secured against accidental operating errors.

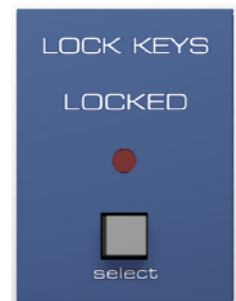

---

## 9. Remote Control

### 9.1 MIDI

The M-32 AD can be completely remote controlled via MIDI. It reacts on special SysEx commands. Furthermore, upon request it will report the complete device status, including all controls and LEDs on the front plate. Each M-32 AD can be programmed with its own ID, providing a separated remote control of multiple devices via a single MIDI channel. A description of the MIDI implementation is found in chapter 19.

The key REMOTE is used to select the source of the MIDI remote control commands: MIDI port, MADI port and Off. The latter is a safety function to prevent any setup-change by any MIDI signal.

The diagram shows the signal flow of the MIDI data with all I/Os. The MIDI input signal reaches both the internal Remote Command Processor and the MIDI outputs. This *MIDI Through* function provides the base for a simplified serial MIDI cabling when using multiple M-32 ADs. The same is true for remote control via MADI, where MIDI is passed through from device to device automatically via the serial MADI cabling.

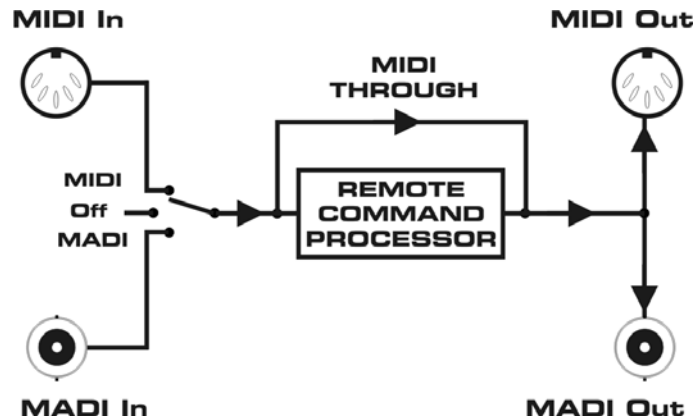

### 9.2 MIDI over MADI

MADI allows for a transmission of 64 audio channels over long distances with a single line – perfect. So what about MIDI? Be it remote control commands or sequencer data, in practice only a single MADI line will not suffice. Therefore RME developed a *MIDI over MADI* technology. The data at the MIDI input are being included into the MADI signal invisibly, and can be collected at the MIDI output of another M-series converter, ADI-8 QS, ADI-6432, ADI-642, ADI-648, Micstasy or a HDSP MADI, at the other end of the MADI line.

Technically every single MADI channel includes several additional bits containing various information (Channel Status). RME uses the usually unused *User bit* of channel 56 (channel 28 in 96k frame mode) to transmit MIDI data invisibly within MADI, ensuring full compatibility.



*Unlike other MADI-based devices from RME, the M-32 AD is no bi-directional MIDI to MADI converter for external signals, because only one direction is available for the transmission.*

The block diagram shows the signal flow in a HDSP MADI-based remote control system. MIDI commands from a software on PC or Mac travel from the MADI Out of the HDSP MADI to the MADI In as well as to the MIDI Out and MADI Out of the M-32 AD.

Additional to the remote commands further MIDI data can be transmitted, available then at the DIN MIDI output jack of the M-32 AD. However, MIDI signals at the DIN input jack can not travel back to the computer. With input setting MIDI the other direction is active. MIDI data travel from the MADI out to the computer, but not back from the computer via MADI to the M-32 AD.

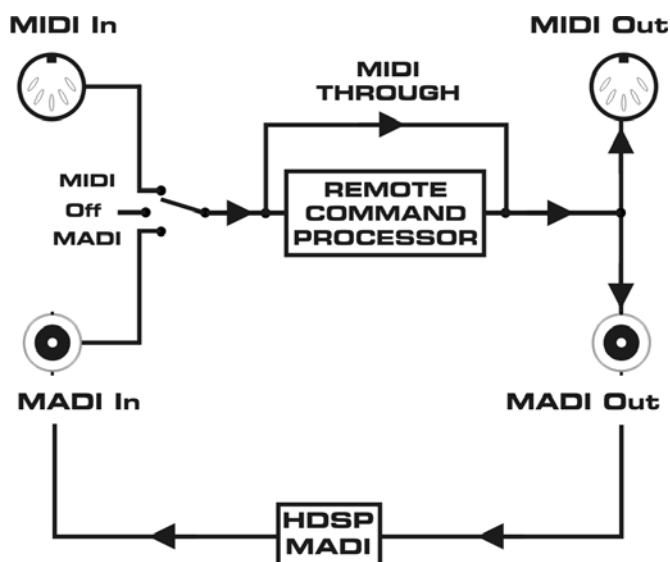

### 9.3 Remote Control Software

A free remote software for Windows and Mac OS X can be downloaded from the RME website. It can use any existing MIDI port within the system to perform remote control and status requests of any number of M-series converters via a simple mouse click. Most appealing is the combination with a HDSP(e) MADI, offering a direct control of the M-32 AD via MADI. The remote control software then uses a virtual MIDI port of the card, which directly sends and receives MIDI data via MADI.

Software download: [http://www.rme-audio.de/en\\_downloads\\_tools.php](http://www.rme-audio.de/en_downloads_tools.php)

#### Brief description of the Windows/Mac OS X Software ADI-8 QS MIDI Remote

The unique multi-window concept of the software **MIDI Remote** allows for a simultaneous usage and configuration not only of multiple M-32 ADs, but also of all other supported devices, even in mixed setups. The function **M-32 AD** has been extended compared to the unit. Settings not available at the unit's front can be controlled, the gain reduction is shown on separate meters etc. Names can be assigned to all channels and all devices.

The program includes an extensive English online help (F1). After the start first choose the function **M-32 AD** in the menu **Functions** (also available via F4).

Then select a MIDI input and output via **Options - MIDI I/O Setup**.

Using the command **Options - Start/Stop MIDI I/O** the communication with the M-32 AD is started. The top line of the program window shows the current state, like selected ID, Online / No Response / Offline etc.

**Save Workspace as** allows to store complete setups including all windows in a file, and to reload them at any time.

**Send Single Set of Data** realizes an offline configuration of the M-32 AD, and uses a single one-time transmission of all settings.

Via MIDI remote control, all front panel controls of the M-32 AD can be locked (**Lock Keys**). An exception is the key LOCK KEYS. Therefore a locking of all the controls can be revoked directly at the unit at any time.

Since firmware 2.1 the fan of the M-32 AD can be set. Additionally the internal temperature of the M-16 and M-32 is displayed.

The software MIDI Remote also controls RME's ADI-648, ADI-6432, ADI-642, Micstasy, ADI-8 QS and the MADi Bridge.

The following functions can only be set via MIDI Remote:

- Setting of Word Clock Out as *Follow Clock* or *Always Single Speed*
- Changing the Device ID
- Fan control

### Fan Modes

#### Cool

In Cool mode the fan runs all time with speed 3. From 48°C up it changes to speed 5 (max.), below 45°C it switches back to speed 3.

#### Normal

Factory default

#### Silent

In Silent mode the fan starts not before 48°C and with highest speed. Below 45°C the fan is switched off again.

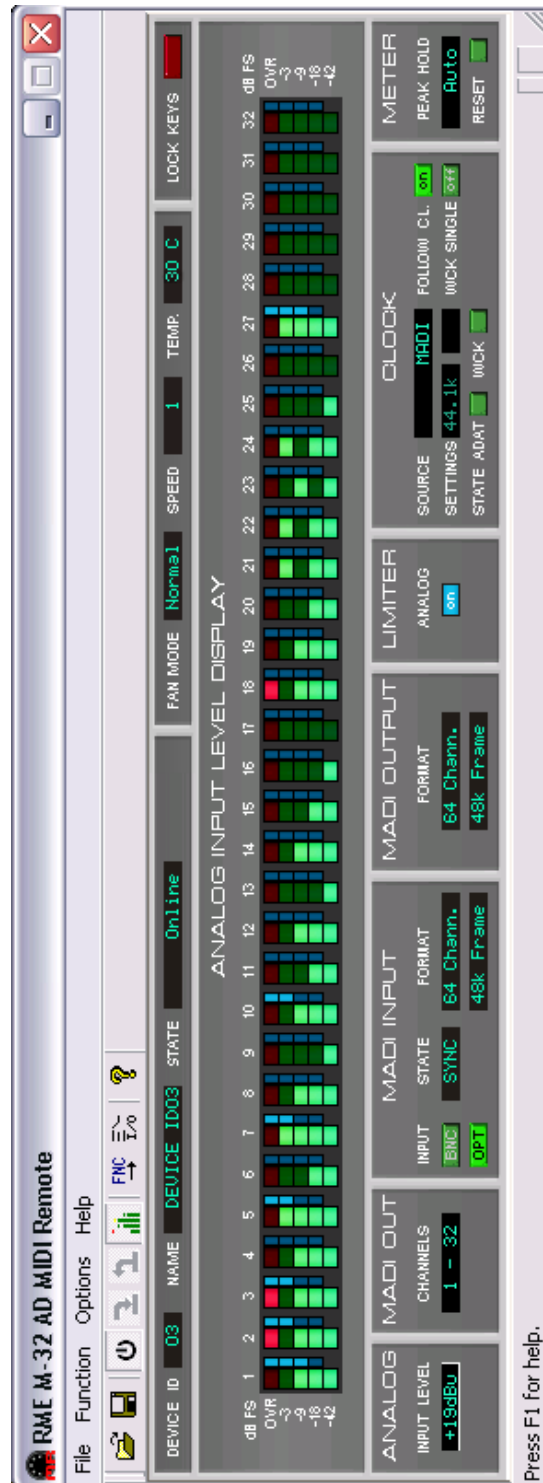

---

## User's Guide



# **M-32 AD**

## **M-16 AD**

### ▶ **Inputs and Outputs**

## 10. Analog Inputs

The M-32 AD's rear has 32 balanced Line inputs, provided by 1/4" TRS and four 25-pin D-sub connectors. Both are internally connected, so can not be used at the same time. The electronic input stage is built in a servo balanced design which handles unbalanced (mono jacks) and balanced (XLR, stereo jacks) signals correctly, automatically adjusting the level reference.

When using unbalanced cables with XLR or TRS connectors be sure to connect pin 3 (- or ring) to 1 (ground). Otherwise noise may occur, caused by the unconnected negative input of the balanced input.

The 25-pin D-sub connector follows the pinout known from devices manufactured by Tascam (pinout see chapter 15.9). Your local dealer will supply analog breakout multicores D-sub to XLR in Tascam pinout in different lengths.

The M-32 AD uses a completely symmetrical signal path (including limiter) that guarantees an exceptional sound quality, outstanding low distortion and highest Signal to Noise ratio in all level settings.

One of the main issues when working with an AD-converter is to maintain the full dynamic range within the best operating level. Therefore the M-32 AD internally uses hi-quality electronic switches, which introduce no additional noise or distortion to the audio path. The key ANALOG INPUT allows for a perfect adaptation of all 32 channels to the most often used studio levels.

Each analog input has its own 5-segment level meter, so every channel can be checked for input signal and overloads easily. The red LED OVR lights up 0.2 dB before full scale level (-0.2 dBFS).

The M-32 AD uses the following level references:

Reference	0 dBFS @	Headroom @ +4 dBu	Other RME devices
+24	+24 dBu	20 dB	-
+19	+19 dBu	15 dB	LoGain
+13	+13 dBu	9 dB	+4 dBu

Set to +24 dBu the M-32 AD is compatible to SMPTE (+24 dBu @ 0 dBFS, +4 dBu with 20 dB of headroom).

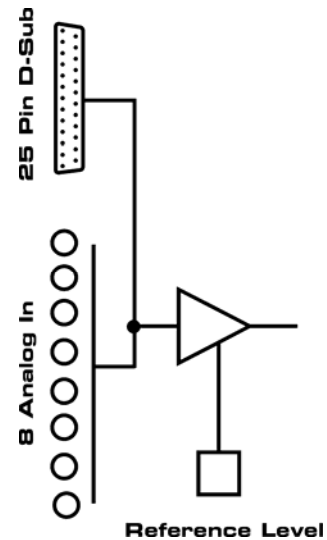

---

## 11. Digital Inputs / Outputs

### 11.1 ADAT Optical

The M-32 AD has an optical ADAT input for optional clock synchronisation, in case word clock or MADI signal are not available. Included audio data are not processed.

Furthermore the unit has 4 optical ADAT outputs. When used with sample rates up to 48 kHz 32 output channels are provided (8 per port). Higher sample rates are transmitted by Sample Multiplexing (S/MUX). Therefore the channel count decreases to 16 channels at Double Speed and 8 channels at Quad Speed.

The ADAT outputs are available up to 192 kHz in parallel to the MADI output, with the above channel limitation.

A usual TOSLINK cable is sufficient for connection.

### 11.2 MADI Input

Both MADI inputs are located on the rear of the M-32 AD.

The BNC input's ground-free design is built according to AES10-1991. The input's impedance is 75 Ohm. It will operate without error from about 180 mVpp.

The optical input uses a FDDI (ISO/IEC 9413-3) compatible optical module, according to AES10-1991. More information can be found in chapter 16.6, MADI Basics.

The ADI-6432 includes automatic input selection. In case the current input signal fails, the unit switches to the other input immediately. This mode, called redundancy mode, offers improved safety against errors on the transmission line. Switching the inputs is done in about one second. The ADI-6432 displays redundancy operation by a blinking LED of the original input, while the input LED of the currently active input will be lit constantly.

The MADI input is used as optional clock source (Clock section, MADI) as well as a through input. Since a M-32 AD uses only 32 channels, it by-passes the remaining 32 channels.

The MADI input serves as optional external clock source, but also as MADI pass-through input. Since the M-32 AD uses only 32 channels of the MADI signal, unused channels of the input signal are fed through to the output.

This technique is used to cascade M-32 ADs serially. Incoming MADI data is passed through unchanged, but 32 channels are replaced by the data of the M-32 AD. This way up to two M-32 AD (four M-16 AD) can be cabled serially via MADI. At the output of the second unit 64 channels M-32 AD are available on one line. The used 32-channel block is set on every unit's front plate via the MADI OUT key.

---

### 11.3 MAD I Output

At the rear side of the M-32 AD there are two MAD I outputs.

The BNC output is built according to AES10-1991. The output's impedance is 75 Ohm. The output voltage will be 600 mVpp when terminated with 75 Ohm.

The optical output uses a FDDI (ISO/IEC 9413-3) compatible optical module, according to AES10-1991. More information can be found in chapter 16.6, MAD I Basics.

Coaxial and optical outputs operate simultaneously and deliver the same data.

The max. channel count when using MAD I depends on the Sample Rate Range. Up to 48 kHz 64 channels can be transmitted, up to 96 kHz 32, and up to 192 kHz 16 channels. That means:

- Up to 48 kHz two M-32 AD or four M-16 AD can be cascaded
- Up to 96 kHz one M-32 AD or two M-16 AD already use all available channels
- Up to 192 kHz one M-16 AD uses all available channels. Channels 17 to 32 of the M-32 AD can not be used.



---

## 12. Word Clock

### 12.1 Word Clock Input and Output

#### Input

The M-32 AD's word clock input is active when WCK is chosen in the clock section. The signal at the BNC input can be Single, Double or Quad Speed, the M-32 AD automatically adapts to it. As soon as a valid signal is detected, the WCK LED is constantly lit, otherwise it is flashing.

Thanks to RME's *Signal Adaptation Circuit*, the word clock input still works correctly even with heavily mis-shaped, dc-prone, too small or overshoot-prone signals. Thanks to automatic signal centering, 300 mV (0.3 V) input level are sufficient in principle. An additional hysteresis reduces sensitivity to 1.0 V, so that over- and undershoots and high frequency disturbances don't cause a wrong trigger.

The word clock input is shipped as high impedance type (not terminated). A push switch allows for activation of internal termination (75 Ohms). The switch is found on the back beside the BNC socket. Use a small pencil or similar and carefully push the blue switch so that it snaps into its lock position and the yellow LED lights up. Another push will release it again and de-activate the termination.

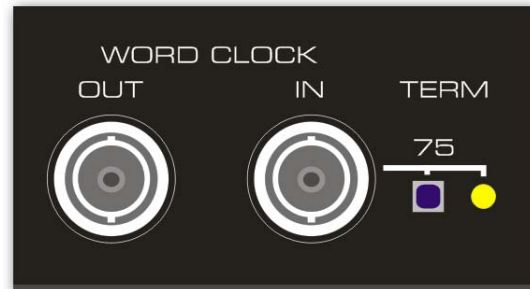

#### Output

The M-32 AD's word clock output is constantly active, providing the current sample frequency as word clock signal. In master mode, the word clock will be fixed to 44.1 kHz or 48 kHz (DS x 2, QS x 4). In any other case the sample rate is identical to the one present at the currently chosen clock input. When the current word clock source fails, the last valid sample rate will be held automatically.

*With activated option Always Single Speed the word clock output will always stay within the range of 32 kHz to 48 kHz. So at 96 kHz and 192 kHz sample rate, the output word clock is 48 kHz.*

The word clock signal received by the M-32 AD can be distributed to other devices by using the word clock output. With this the usual T-adaptor can be avoided, and the M-32 AD operates as *Signal Refresher*. This kind of operation is highly recommended, because

- Input and output are phase-locked and in phase (0°) to each other
- SteadyClock removes nearly all jitter from the input signal
- the exceptional input (1 Vpp sensitivity instead of the usual 2.5 Vpp, dc cut, Signal Adaptation Circuit) plus SteadyClock guarantee a secure function also with most critical word clock signals.

Thanks to a low impedance, but short circuit proof output, the M-32 AD delivers 4 Vpp to 75 Ohms. For wrong termination with 2 x 75 Ohms (37.5 Ohms), there are still 3.3 Vpp at the output.

---

## 12.2 Operation and Technical Background

In the analog domain one can connect any device to another device, a synchronization is not necessary. Digital audio is different. It uses a clock, the sample frequency. The signal can only be processed and transmitted when all participating devices share the same clock. If not, the signal will suffer from wrong samples, distortion, crackle sounds and drop outs.

AES/EBU, SPDIF, ADAT and MADI are self-clocking, an additional word clock connection in principle isn't necessary. But when using more than one device simultaneously problems are likely to happen. For example any self-clocking will not work in a loop cabling, when there is no 'master' (main clock) inside the loop. Additionally the clock of all participating devices has to be synchronous. This is often impossible with devices limited to playback, for example CD players, as these have no SPDIF input, thus can't use the self clocking technique as clock reference.

In a digital studio synchronisation is maintained by connecting all devices to a central sync source. For example the mixing desk works as master and sends a reference signal, the word clock, to all other devices. Of course this will only work as long as all other devices are equipped with a word clock or sync input, thus being able to work as slave (some professional CD players indeed have a word clock input). Then all devices get the same clock and will work in every possible combination with each other.



*Remember that a digital system can have one master only!*

But word clock is not only the 'great problem solver', it also has some disadvantages. The word clock is based on a fraction of the really needed clock. For example SPDIF: 44.1 kHz word clock (a simple square wave signal) has to be multiplied by 256 inside the device using a special PLL (to about 11.2 MHz). This signal then replaces the one from the quartz crystal. Big disadvantage: because of the high multiplication factor the reconstructed clock will have great deviations called jitter. The jitter of a word clock is much higher as when using a quartz based clock.

The end of these problems should have been the so called Superclock, which uses 256 times the word clock frequency. This equals the internal quartz frequency, so no PLL for multiplying is needed and the clock can be used directly. But reality was different, the Superclock proved to be much more critical than word clock. A square wave signal of 11 MHz distributed to several devices - this simply means to fight with high frequency technology. Reflections, cable quality, capacitive loads - at 44.1 kHz these factors may be ignored, at 11 MHz they are the end of the clock network. Additionally it was found that a PLL not only generates jitter, but also rejects disturbances. The slow PLL works like a filter for induced and modulated frequencies above several kHz. As the Superclock is used without any filtering such a kind of jitter and noise suppression is missing. In the end Superclock did not become a commonly accepted standard.

The actual end of these problems is offered by the **SteadyClock** technology of the M-series. Combining the advantages of modern and fastest digital technology with analog filter techniques, re-gaining a low jitter clock signal of 22 MHz from a slow word clock of 44.1 kHz is no problem anymore. Additionally, jitter on the input signal is highly rejected, so that even in real world usage the re-gained clock signal is of highest quality.

---

## 12.3 Cabling and Termination

Word clock signals are usually distributed in the form of a network, split with BNC T-adapters and terminated with resistors. We recommend using off-the-shelf BNC cables to connect all devices, as this type of cable is used for most computer networks. Actually you will find all the necessary components (T-adapters, terminators, cables) in most electronics and computer stores. The latter usually carries 50 Ohm components. The 75 Ohm components used for word clock are part of video technology (RG59).

Ideally, the word clock signal is a 5 Volt square wave with the frequency of the sample rate, of which the harmonics go up to far above 500 kHz. To avoid voltage loss and reflections, both the cable itself and the terminating resistor at the end of the chain should have an impedance of 75 Ohm. If the voltage is too low, synchronization will fail. High frequency reflection effects can cause both jitter and sync failure.

Unfortunately there are still many devices on the market, even newer digital mixing consoles, which are supplied with a word clock output that can only be called unsatisfactory. If the output breaks down to 3 Volts when terminating with 75 Ohms, you have to take into account that a device, of which the input only works from 2.8 Volts and above, does not function correctly already after 3 meter cable length. So it is not astonishing that because of the higher voltage, word clock networks are in some cases more stable and reliable if cables are not terminated at all.

Ideally all outputs of word clock delivering devices are designed as low impedance types, but all word clock inputs as high impedance types, in order to not weaken the signal on the chain. But there are also negative examples, when the 75 Ohms are built into the device and cannot be switched off. In this case the network load is often 2 x 75 Ohms, and the user is forced to buy a special word clock distributor. Note that such a device is generally recommended for larger studios.

The M-32 AD's word clock input can be high-impedance or terminated internally, ensuring maximum flexibility. If termination is necessary (e.g. because the M-32 AD is the last device in the chain), push the switch at the back (see chapter 12.1).

In case the M-32 AD resides within a chain of devices receiving word clock, plug a T-adapter into its BNC input jack, and the cable supplying the word clock signal to one end of the adapter. Connect the free end to the next device in the chain via a further BNC cable. The last device in the chain should be terminated using another T-adapter and a 75 Ohm resistor (available as short BNC plug). Of course devices with internal termination do not need T-adapter and terminator plug.



*Due to the outstanding SteadyClock technology of the M-32 AD, we recommend to not pass the input signal via T-adapter, but to use the unit's word clock output instead. Thanks to SteadyClock, the input signal will both be freed from jitter and - in case of loss or drop out - be held at the last valid frequency.*

## 14. MIDI

The M-32 AD has a standard MIDI input and output, a 5-pin DIN jack each. The MIDI I/O is used for:

- remote control of the M-32 AD, see chapter 9.1
- transmission of MIDI data and remote control commands over MADI, see chapter 9.2





---

## User's Guide



# **M-32 AD**

## **M-16 AD**

▶ **Technical Reference**

---

## 15. Technical Specifications

### 15.1 Analog

#### Line In 1-8, TRS/D-Sub

- Input: 6.3 mm TRS jack and D-sub 25-pin, servo-balanced
- Input impedance: 10 kOhm
- Input sensitivity switchable +24 dBu, +19 dBu, +13 dBu @ 0 dBFS

#### Analog Limiter

- Maximum analog input level unclipped: +30 dBu
- Threshold On: -3 dBFS
- Threshold Off: +3 dB
- THD+N: 0.03%, -52 dB
- Attack time: 5 ms
- Release time: 2-step, digitally controlled

#### AD-Conversion

- Resolution: 24 bit
- Signal to Noise ratio (SNR) @ +24 dBu, 44.1 kHz: 112.9 dB RMS unweighted, 117 dBA
- Signal to Noise ratio (SNR) @ +19 dBu: 112.7 dB RMS unweighted, 116 dBA
- Signal to Noise ratio (SNR) @ +13 dBu: 112.2 dB RMS unweighted, 116 dBA
- Frequency response @ 44.1 kHz, -0,5 dB: 5 Hz – 21.5 kHz
- Frequency response @ 96 kHz, -0,5 dB: 5 Hz – 45.5 kHz
- Frequency response @ 192 kHz, -1 dB: 5 Hz – 66.5 kHz
- THD: < -110 dB, < 0.00032 %
- THD+N: < -104 dB, < 0.00063 %
- Channel separation: > 110 dB

### 15.2 Digital Inputs

#### ADAT Optical

- 1 x TOSLINK, according to Alesis specification
- Bitclock PLL ensures perfect synchronisation even in varispeed operation
- Lock Range: 31.5 kHz – 50 kHz
- Jitter when synced to input signal: < 1 ns
- Jitter suppression: > 30 dB (2.4 kHz)

#### Word Clock

- BNC, not terminated (10 kOhm)
- Switch for internal termination 75 Ohm
- Automatic Double/Quad Speed detection and internal conversion to Single Speed
- SteadyClock guarantees super low jitter synchronization even in varispeed operation
- Not affected by DC-offsets within the network
- Signal Adaptation Circuit: signal refresh through auto-center and hysteresis
- Overvoltage protection
- Level range: 1.0 Vpp – 5.6 Vpp
- Lock Range: 27 kHz – 200 kHz
- Jitter when synced to input signal: < 1 ns
- Jitter suppression: > 30 dB (2.4 kHz)

---

## **MADI**

- Coaxial via BNC, 75 Ohm, according to AES10-1991
- High-sensitivity input stage (< 0.2 Vpp)
- Optical via FDDI duplex SC connector
- 62.5/125 and 50/125 compatible
- Accepts 56 channel and 64 channel mode, and 96k frame
- Single Wire: up to 64 channels 24 bit 48 kHz
- Double Wire / 96k frame: up to 32 channels 24 bit 96 kHz
- Quad Wire: up to 16 channels 24 bit 192 kHz
- Lock range: 28 kHz – 54 kHz
- Jitter when synced to input signal: < 1 ns
- Jitter suppression: > 30 dB (2.4 kHz)

## **15.3 Digital Outputs**

### **ADAT**

- 4 x TOSLINK
- Standard: 32 channels 24 bits, up to 48 kHz
- S/MUX: 16 channels 24 bits 96 kHz
- S/MUX4: 8 channels 24 bits 192 kHz

### **MADI**

- Coaxial via BNC, 75 Ohm, according to AES10-1991
- Output voltage 600 mVpp
- Cable length coaxial: up to 100 m
- Optical via FDDI duplex SC connector
- 62.5/125 and 50/125 compatible
- Cable length optical up to 2.000 m
- Generates 56 channel and 64 channel mode, and 96k frame
- Single Wire: up to 64 channels 24 bit 48 kHz
- Double Wire / 96k frame: up to 32 channels 24 bit 96 kHz
- Quad Wire: up to 16 channels 24 bit 192 kHz

### **Word Clock**

- BNC
- Max. output voltage: 5 Vpp
- Output voltage @ 75 Ohm: 4.0 Vpp
- Impedance: 10 Ohm
- Frequency range: 27 kHz – 200 kHz

## **15.4 Digital**

- Clocks: Internal, ADAT In, MADI In, Word Clock In
- Low Jitter Design: < 1 ns in PLL mode, all inputs
- Internal clock: 800 ps Jitter, Random Spread Spectrum
- Jitter suppression of external clocks: > 30 dB (2.4 kHz)
- Effective clock jitter influence on AD-conversion: near zero
- PLL ensures zero dropout, even at more than 100 ns jitter
- Supported sample rates: 28 kHz up to 200 kHz

---

## 15.5 MIDI

- 16 channels MIDI
- 5-pin DIN jacks
- Optocoupled, ground-free input

### MADI

- Invisible transmission via User bit of channel 56 (48k frame)

## 15.6 General

- Dimensions including rack ears (WxHxD): 483 x 88 x 242 mm (19" x 3.46" x 9.5")
- Dimensions without rack ears/handles (WxHxD): 436 x 88 x 235 mm (17.2" x 3.46" x 9.3")
- Temperature range: +5° up to +50° Celsius (41° F up to 122°F)
- Relative humidity: < 75%, non condensing

### M-32 AD

- Power supply: Internal switching PSU, 100 - 240 V AC, 40 Watt
- Typical power consumption: 23 Watt
- Max. power consumption: < 30 Watt
- Weight: 3 kg ( 6.6 lbs)

### M-16 AD

- Power supply: Internal switching PSU, 100 - 240 V AC, 40 Watt
- Typical power consumption: 15 Watt
- Max. power consumption: < 20 Watt
- Weight: 2.5 kg ( 5.5 lbs)

## 15.7 Firmware

The M-Series is internally based on programmable logic. By re-programming of a little component called Flash-PROM, both function and behaviour of the unit can be changed at any time.

At the time of writing this manual, M-32 AD and M-16 AD are shipped with firmware 1.5. The firmware version is displayed after power on for about one second on the level meters of the M-series units.

Firmware 1.5: Initial release

Firmware 2.1: ADAT Copy mode for M-16 AD (in Single Speed operation the M-16 AD mirrors the output signal, so all 4 ADAT outputs are used). The temperature inside the unit can be read via MIDI. The fan operation can be changed via MIDI.

## 15.8 MADI User Bit Chart

- RS-232: channels 1 to 9 (passed-through by the M-series)
- ADC: channel 19
- MIDI: channel 56 (48k) / 28 (96k)



---

## 15.9 Connector Pinouts

### D-Sub Analog Inputs

The 25 pin D-sub connectors of the analog inputs are wired according to the Tascam scheme, as shown in this table:

Chan.	1+	1-	2+	2-	3+	3-	4+	4-	5+	5-	6+	6-	7+	7-	8+	8-
D-sub	24	12	10	23	21	9	7	20	18	6	4	17	15	3	1	14

GND is connected to pins 2, 5, 8, 11, 16, 19, 22, 25. Pin 13 is unconnected.

The servo balanced input circuitry allows to use unbalanced connections with no loss in level. For this to work, pins 3 (-) and 1 (GND) have to be connected.

### TRS jacks analog inputs / outputs

The stereo ¼" TRS jacks of the analog inputs are wired according to international standards:

Tip = + (hot)  
Ring = - (cold)  
Sleeve = GND

The servo-balanced circuitry accepts monaural TS jacks (unbalanced) with no loss in level, equalling a TRS-jack with its ring connected to ground.

---

## 16. Technical Background

### 16.1 Terminology

#### Single Speed

Sample rate range originally used in Digital Audio. Typical applications are 32 kHz (digital radio broadcast), 44.1 kHz (CD), and 48 kHz (DAT).

#### Double Speed

Doubles the original sample rate range, in order to achieve higher audio quality and improved audio processing. 64 kHz is practically never used, 88.2 kHz is quite rare in spite of certain advantages. 96 kHz is a common format. Sometimes called **Double Fast**.

#### Quad Speed

Controversially discussed way of ensuring hi-end audio quality and processing by quadrupling the sample frequency. 128 kHz is non-existent, 176.4 kHz is rare, if at all then 192 kHz is used, e.g. for DVD Audio.

#### Single Wire

Standard audio data transfer, where the audio signal's sample rate is equal to the rate of the digital signal. Used from 32 to 192 kHz. Sometimes called **Single Wide**.

#### Double Wire

Before 1998 there were no receiver/transmitter circuits available that could receive or transmit more than 48 kHz. Higher sample rates were transferred by splitting odd and even bits across the L/R channels of a single AES connection. This provides for twice the data rate, and hence twice the sample rate. A stereo signal subsequently requires two AES/EBU ports.

The Double Wire method is an industry standard today, however it has a number of different names, like **Dual AES**, **Double Wide**, **Dual Line** and **Wide Wire**. The AES3 specification uses the uncommon term *Single channel double sampling frequency mode*. When used with the ADAT format, the term S/MUX is commonly used.

Double Wire not only works with Single Speed signals, but also with Double Speed. As an example, Pro Tools HD, whose AES receiver/transmitter only work up to 96 kHz, uses Double Wire to transmit 192 kHz. Four channels of 96 kHz turn into two channels of 192 kHz.

#### Quad Wire

Similar to Double Wire, with samples of one channel spread across four channels. This way single speed devices can transmit up to 192 kHz, but need two AES/EBU ports to transmit one channel. Also called **Quad AES**.

#### S/MUX

Since the ADAT hardware interface is limited to Single Speed, the Double Wire method is used for sample rates up to 96 kHz, but usually referred to as S/MUX (Sample Multiplexing). An ADAT port supports four channels this way.

#### S/MUX4

The Quad Wire method realizes the transmission of two channels at up to 192 kHz via ADAT. The method is referred to as S/MUX4.

**Note:** All conversions of the described methods are lossless. The existing samples are just spread or re-united between the channels.

---

## 16.2 Lock and SyncCheck

Digital signals consist of a carrier and the data. If a digital signal is applied to an input, the receiver has to synchronize to the carrier clock in order to read the data correctly. To achieve this, the receiver uses a PLL (Phase Locked Loop). As soon as the receiver meets the exact frequency of the incoming signal, it is locked. This **Lock** state remains even with small changes of the frequency, because the PLL tracks the receiver's frequency.

If an ADAT or MADI signal is applied to the M-32 AD, the corresponding LED starts flashing. The unit indicates LOCK, i.e. a valid input signal (in case the signal is in sync, the LED is constantly lit, see below).

Unfortunately, LOCK does not necessarily mean that the received signal is correct with respect to the clock which processes the read out of the embedded data. Example: The M-32 AD is set to 44.1 kHz internal clock (clock mode master), and a mixing desk with MADI output is connected to the MADI input. The MADI LED will start flashing immediately, because the mixing desk's sample rate is generated internally, and thus slightly higher or lower than the M-32 AD's internal sample rate. Result: When reading out the data, there will frequently be read errors that cause clicks and drop outs.

Also when using multiple inputs, a simple LOCK is not sufficient. The above described problem can be solved elegantly by setting the M-32 AD from internal clock to MADI (its internal clock will then be the clock delivered by the mixing desk). But in case another asynchronous device is connected, there will again be a slight difference in the sample rate, and therefore clicks and drop outs.

In order to display those problems optically at the device, the M-series includes **SyncCheck**<sup>®</sup>. It checks all clocks used for *synchronicity*. If they are not synchronous to each other (i.e. absolutely identical) the LED of the asynchronous input will flash. In case they are synchronous the LED stays dark, only the LED of the current clock source will be lit (constantly). In the above example it would have been obvious that the MADI LED starts flashing after connecting the mixing desk.

In practice, SyncCheck allows for a quick overview of the correct configuration of all digital devices. This way one of the most difficult and error-prone topics of the digital studio world finally becomes easy to handle.

---

## 16.3 Latency and Monitoring

The term **Zero Latency Monitoring** has been introduced by RME in 1998 for the DIGI96 series and describes the ability to pass-through the computer's input signal at the interface directly to the output. Since then, the idea behind has become one of the most important features of modern hard disk recording. In the year 2000, RME published two ground-breaking Tech Infos on the topics *Low Latency Background*, which are still up-to-date: *Monitoring, ZLM and ASIO*, and *Buffer and Latency Jitter*, found on the RME website.

### How much Zero is Zero?

From a technical view there is no zero. Even the analog pass-through is subject to phase errors, equalling a delay between input and output. However, delays below certain values can subjectively be claimed to be a zero-latency. This applies to analog routing and mixing, and in our opinion also to RME's Zero Latency Monitoring. RME's digital receiver's buffer and the output via the transmitter cause a typical delay of 3 samples. At 44.1 kHz this equals about 68  $\mu$ s (0.000068 s), at 192 kHz only 15  $\mu$ s.

### Oversampling

While the delays of digital interfaces can be disregarded altogether, the analog inputs and outputs do cause a significant delay. Modern converter chips operate with 64 or 128 times oversampling plus digital filtering, in order to move the error-prone analog filters away from the audible frequency range as far as possible. This typically generates a delay of about 40 samples, equalling one millisecond. A playback and re-record of the same signal via DA and AD (loop-back) then causes an offset of the newly recorded track of about 2 ms.

The exact delays of the M-32 AD are:

Sample rate kHz	44.1	48	88.2	96	176.4	192
AD (37 x 1/fs) ms	0.84	0.77	0.42	0.38		
AD (9.5 x 1/fs) ms					0.054	0.05

---

## 16.4 DS - Double Speed

When activating the *Double Speed* mode the M-32 AD operates at double sample rate. The internal clock 44.1 kHz turns to 88.2 kHz, 48 kHz to 96 kHz. The internal resolution is still 24 bit.

Sample rates above 48 kHz were not always taken for granted, and are still not widely used because of the CD format (44.1 kHz) dominating everything. Before 1998 there were no receiver/transmitter circuits available that could receive or transmit more than 48 kHz. Therefore a work-around was used: instead of two channels, one AES line only carries one channel, whose odd and even samples are being distributed to the former left and right channels. By this, you get the double amount of data, i. e. also double sample rate. Of course in order to transmit a stereo signal two AES/EBU ports are necessary then.

This transmission mode is called *Double Wire* in the professional studio world, and is also known as *S/MUX (Sample Multiplexing)* in connection with the ADAT format.

Not before February 1998, Crystal shipped the first 'single wire' receiver/transmitters that could also work with double sample rate. It was then possible to transmit two channels of 96 kHz data via one AES/EBU port.

But *Double Wire* is still far from being dead. On one hand, there are still many devices which can't handle more than 48 kHz, e. g. digital tape recorders. But also other common interfaces like ADAT or TDIF are still using this technique.

Because the ADAT interface does not allow for sampling frequencies above 48 kHz (a limitation of the interface hardware), the M-32 AD automatically uses *Sample Multiplexing* in DS mode. One channel's data is distributed to two channels according to the following table:

Analog In	1	2	3	4	5	6	7	8
DS Signal	1/2	3/4	5/6	7/8	1/2	3/4	5/6	7/8
ADAT Port	1	1	1	1	2	2	2	2

As the transmission of double rate signals is done at standard sample rate (Single Speed), the ADAT outputs still deliver 44.1 kHz or 48 kHz.

## 16.5 QS – Quad Speed

An implementation of the ADAT format as double S/MUX (S/MUX4) results in only two channels per optical output. There are few devices using this method.

In Quad Speed mode the M-32 AD automatically uses *Sample Multiplexing*. One channel's data is distributed to four channels according to the following table:

Analog In	1	2	3	4	5	6	7	8
QS Signal	1/2/3/4	5/6/7/8	1/2/3/4	5/6/7/8	1/2/3/4	5/6/7/8	1/2/3/4	5/6/7/8
ADAT Port	1	1	2	2	3	3	4	4

As the transmission of quad rate signals is done at standard sample rate (Single Speed), the ADAT output still delivers 44.1 kHz or 48 kHz.

---

## 16.6 MADl Basics

MADl, the serial **M**ultichannel **A**udio **D**igital **I**nterface, has been defined already in 1989 as an extension of the existing AES3 standard following several manufacturers' wish. The format also known as AES/EBU, a balanced bi-phase signal, is limited to two channels. Simply put, MADl contains 28 of those AES/EBU signals in serial, i. e. after one another, and the sample rate can still even vary by +/-12.5%. The limit which cannot be exceeded is a data rate of 100Mbit/s.

Because an exact sampling frequency is used in most cases, the 64 channel mode was introduced officially in 2001. It allows for a maximum sample rate of 48 kHz + ca. 1%, corresponding to 32 channels at 96 kHz, without exceeding the maximum data rate of 100 Mbit/s. The effective data rate of the port is 125 Mbit/s due to additional coding.

Older devices understand and generate only the 56 channel format. Newer devices often work in the 64 channel format, but offer still no more than 56 audio channels. The rest is being eaten up by control commands for mixer settings etc.. RME units show that this can be done in a much better way, with an invisible transmission of 16 MIDI channels plus serial RS232 data stream, and the 64-channel MADl signal still being 100% compatible.

For the transmission of the MADl signal, proved methods known from network technology were applied. Most people know unbalanced (coaxial) cables with 75 Ohms BNC plugs, they are not expensive and easy to get. The optical interface is much more interesting due to its complete galvanic separation, but for many users it is a mystery, because very few have ever dealt with huge cabinets full of professional network technology. Therefore here are some explanations regarding 'MADl optical'.

- The cables used are standard in computer network technology. They are thus not at all expensive, but unfortunately not available in every computer store.
- The cables have an internal fibre of only 50 or 62.5 µm diameter and a coating of 125 µm. They are called network cables 62.5/125 or 50/125, the former mostly being blue and the latter mostly being orange. Although in many cases not clearly labelled, these are always (!) glass fibre cables. Plastic fibre cables (POF, plastic optical fibre) can not be manufactured in such small diameters.
- The plugs used are also an industry standard and called SC. Please don't mix them up with ST connectors, which look similar to BNC connectors and are being screwed. Plugs used in the past (MIC/R) were unnecessarily big and are not being used any longer.
- The cables are available as a duplex variant (2 cables being glued together) or as a simplex variant (1 cable). The M-series' optical module supports both variants.
- The transmission uses the multimode technique which supports cable lengths of up to almost 2 km. Single mode allows for much longer distances, but it uses a completely different fibre (8 µm). Due to the wave-length of the light being used (1300 nm) the optical signal is invisible to the human eye.

## 16.7 SteadyClock

The SteadyClock technology of the M-series guarantees an excellent performance in all clock modes. Its highly efficient jitter suppression refreshes and cleans up any clock signal, and provides it as reference clock at the word clock output.

Usually a clock section consists of an analog PLL for external synchronization and several quartz oscillators for internal synchronisation. SteadyClock requires one quartz only, using a frequency not equalling digital audio. Latest circuit designs like hi-speed digital synthesizer, digital PLL, 100 MHz sample rate and analog filtering allow RME to realize a completely newly developed clock technology, right within the FPGA at lowest costs. The clock's performance exceeds even professional expectations. Despite its remarkable features, SteadyClock reacts quite fast compared to other techniques. It locks in fractions of a second to the input signal, follows even extreme varipitch changes with phase accuracy, and locks directly within a range of 28 kHz up to 200 kHz.

SteadyClock has originally been developed to gain a stable and clean clock from the heavily jittery MADI data signal. The embedded MADI clock suffers from about 80 ns jitter, caused by the time resolution of 125 MHz within the format. Common jitter values for other devices are 5 ns, while a very good clock will have less than 2 ns.

The picture to the right shows the MADI input signal with 80 ns of jitter (top graph, yellow). Thanks to SteadyClock this signal turns into a clock with less than 2 ns jitter (lower graph, blue).

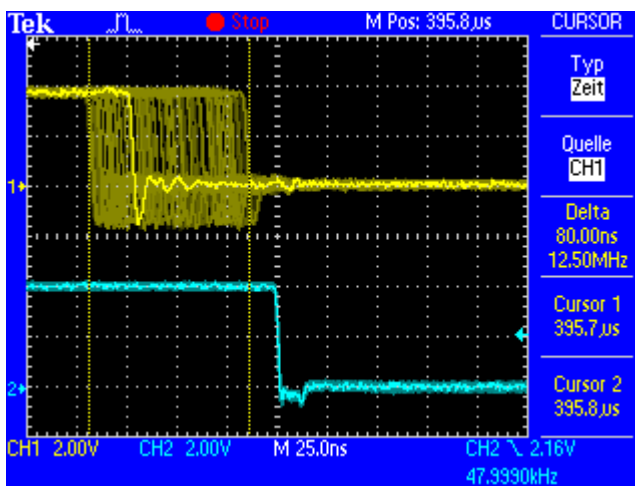

Using the other input sources of the M-32 AD, word clock and ADAT, you'll most probably never experience such high jitter values. But SteadyClock is not only ready for these, it would also handle them just on the fly.

The screenshot to the right shows an extremely jittery word clock signal of about 50 ns jitter (top graph, yellow). Again SteadyClock provides an extreme clean-up. The filtered clock shows less than 2 ns jitter (lower graph, blue).

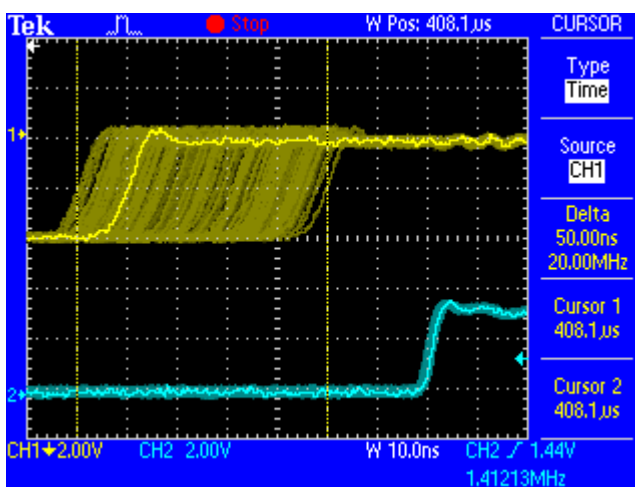

The cleaned and jitter-free signal can be used as reference clock for any application, without any problem. The signal processed by SteadyClock is of course not only used internally, but also available at the units word clock output. It is also used to clock the digital outputs MADI and ADAT.

# 17. Block Diagram M-32 AD

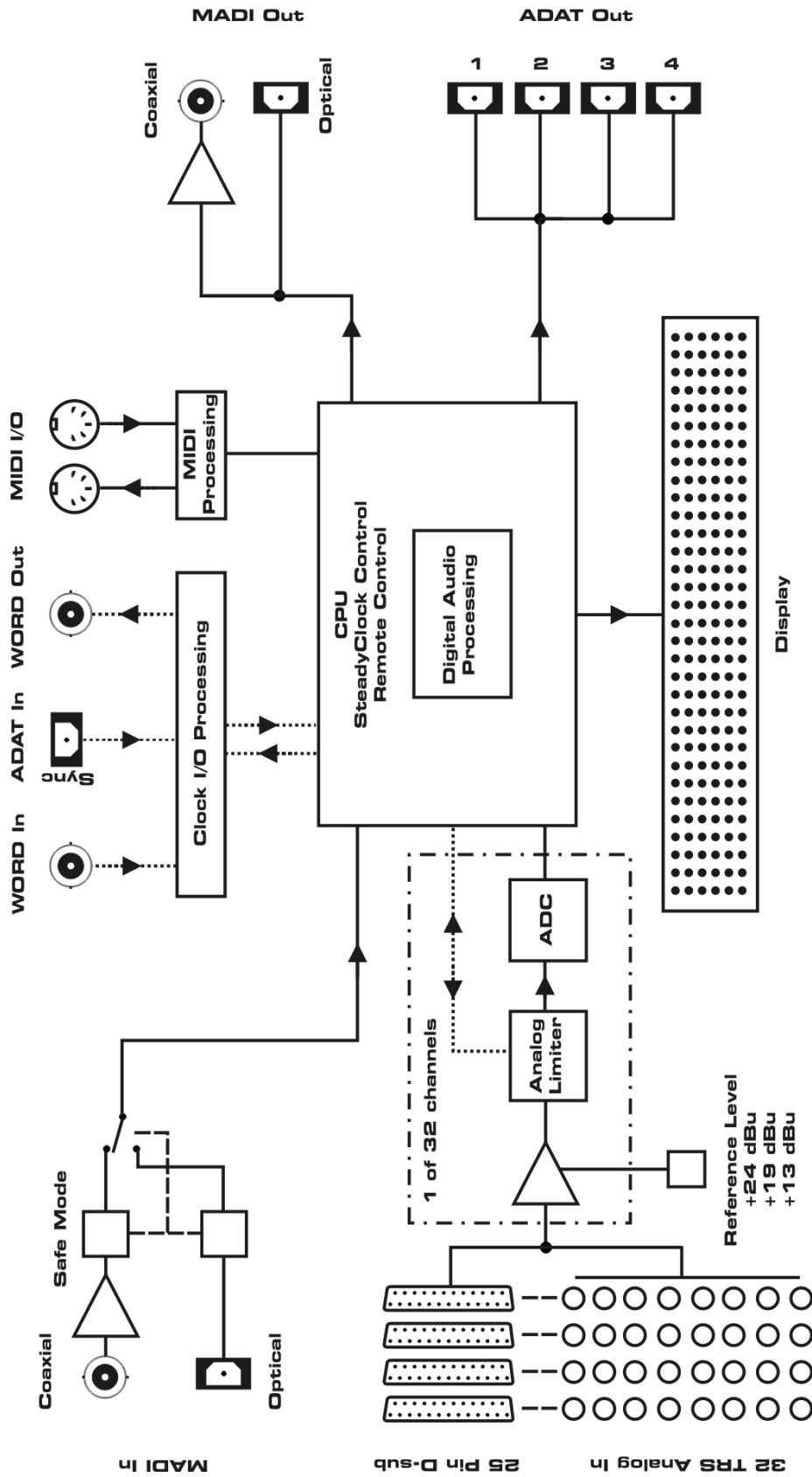



## 18. Block Diagram M-16 AD

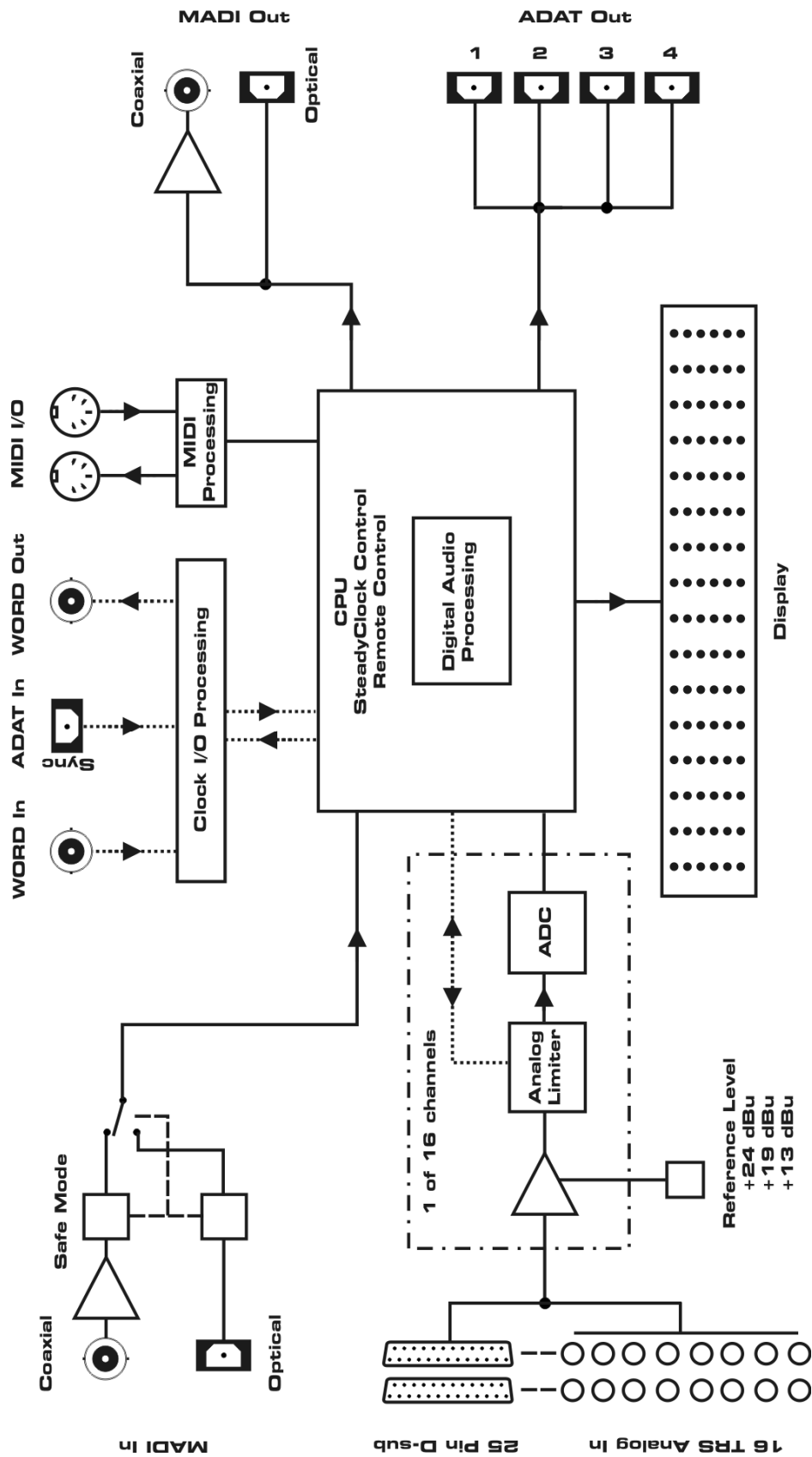

---

## 19. MIDI Implementation M-Series

### 19.1 Basic SysEx Format

<u>Value</u>	<u>Name</u>
F0h	SysEx header
00h 20h 0Dh	MIDITEMP manufacturer ID
32h	Model ID (M-Series)
00h..7Eh, 7Fh	Bank number / device ID (7Fh = broadcast, all IDs)
mm	Message type
nn	Parameter number (see table 1)
oo	Data byte
F7h	EOX

#### Bank Number / Device ID

The lower nibble refers to the device ID (0..7), the higher nibble refers to the bank number (0..7), e. g. 25h means bank 2, device 5. 7Fh addresses all banks and all devices.

### 19.2 Message Types

<u>Value</u>	<u>Name</u>
10h	Request value
20h	Set value
30h	Value response

#### Request Value

Format: F0 00 20 0D 32 (bank no. / dev ID) 10 F7

This string triggers a complete dump of all value response data bytes including the level meter data.

#### Set Value

Sets any number of parameters.

nn / oo can be repeated freely.

#### Value Response

After being triggered by receiving a request value command, device sends a string of all value response data bytes. Message type is set to 30h.

### 19.3 Table

No.	No.	Name	Set Val.	Val. Resp.	Data bytes
00h	0	settings byte 1	x	x	hex coded value of byte (see below)
01h	1	settings byte 2	x	x	hex coded value of byte (see below)
02h	2	settings byte 3	x	x	hex coded value of byte (see below)
03h	3	info byte 1		x	hex coded value of byte (see below)
04h	4	info byte 2		x	hex coded value of byte (see below)
05h	5	info byte 3		x	hex coded value of byte (see below)
06h	6	info byte 4		x	hex coded value of byte (see below)
07h	7	level ch 01		x	(see below)
08h	8	level ch 02		x	(see below)
09h	9	level ch 03		x	(see below)
0Ah	10	level ch 04		x	(see below)
0Bh	11	level ch 05		x	(see below)
0Ch	12	level ch 06		x	(see below)
0Dh	13	level ch 07		x	(see below)
0Eh	14	level ch 08		x	(see below)
0Fh	15	level ch 09		x	(see below)
10h	16	level ch 10		x	(see below)
11h	17	level ch 11		x	(see below)
12h	18	level ch 12		x	(see below)
13h	19	level ch 13		x	(see below)
14h	20	level ch 14		x	(see below)
15h	21	level ch 15		x	(see below)
16h	22	level ch 16		x	(see below)
17h	23	level ch 17		x	(see below)
18h	24	level ch 18		x	(see below)
19h	25	level ch 19		x	(see below)
1Ah	26	level ch 20		x	(see below)
1Bh	27	level ch 21		x	(see below)
1Ch	28	level ch 22		x	(see below)
1Dh	29	level ch 23		x	(see below)
1Eh	30	level ch 24		x	(see below)
1Fh	31	level ch 25		x	(see below)
20h	32	level ch 26		x	(see below)
21h	33	level ch 27		x	(see below)
22h	34	level ch 28		x	(see below)
23h	35	level ch 29		x	(see below)
24h	36	level ch 30		x	(see below)
25h	37	level ch 31		x	(see below)
26h	38	level ch 32		x	(see below)
27h	39	fan control		x	(see below)
28h	40	temperature		x	(see below)
29h	41	(reserved)		x	
30h	42	(reserved)		x	
31h	43	set device id	x		(response displays in header)

00h	0	settings byte 1	MSB / 7		0
			6		madi input: 0 = BNC, 1 = opt
			5		madi frame: 0 = 48k, 1 = 96k
			4		madi format: 0 = 56ch, 1 = 64ch
			3	MSB / 1	madi channels: 0 = 1ff, 1 = 16ff,
			2	LSB / 0	2 = 32ff, 3 = 48ff
			1		0
			LSB / 0		input madi / adat: 0 = madi, 1 = adat

01h	1	settings byte 2	MSB / 7		0
			6	MSB / 2	clock select: 0 = int 44.1, 1 = int 48, 2 = WCK
			5	1	clock select: 3 = MADI, 4 = ADAT
			4	LSB / 0	clock select
			3		clock out: 0 = Fs, 1 = always single speed
			2		follow clock: 0 = off, 1 = on
			1	MSB / 1	clock state: 0 = single speed, 1 = ds, 2 = qs
			LSB / 0	LSB / 0	clock state

02h	2	settings byte 3	MSB / 7		0
			6	MSB / 1	analog level: 0 = +13, 1 = +19, 2 = +24
			5	LSB / 0	analog level
			4		limiter: 0 = off, 1 = on
			3	MSB / 1	Peak Hold: 0 = off, 1 = auto reset,
			2	LSB / 0	Peak Hold: 2 = manual, 3 = reset (tx only)
			1		0
			LSB / 0		lock keys: 0 = unlock, 1 = lock

03h	3	info byte 1	MSB / 7		0
			6		MADI input override
			5		MADI lock
			4		MADI sync
			3		MADI input 96k frame
			2		MADI input 64ch
			1		model subtype: 0 = M-16, 1 = M-32
			LSB / 0		model subtype: 0 = AD, 1 = DA

04h	4	info byte 2	MSB / 7		0
			6		WCK lock
			5		WCK Input 192k
			4		WCK Input 96k
			3		0
			2		0
			1		ADAT Ref (AD) or 1 (DA) Sync: 0 = no sync, 1 = sync
			LSB / 0		ADAT Ref (AD) or 1 (DA) Lock: 0 = unlock, 1 = lock

05h	5	info byte 3	MSB / 7		0
			6		0
			5		ADAT 2 Sync: 0 = no sync, 1 = sync
			4		ADAT 2 Lock: 0 = unlock, 1 = lock
			3		ADAT 3 Sync: 0 = no sync, 1 = sync
			2		ADAT 3 Lock: 0 = unlock, 1 = lock
			1		ADAT 4 Sync: 0 = no sync, 1 = sync
			LSB / 0		ADAT 4 Lock: 0 = unlock, 1 = lock

06h	6	info byte 4	MSB / 7		0
			6		0
			5		0
			4		0
			3		0
			2		0
			1	MSB / 1	MIDI remote: 0 = off, 1 = DIN, 2 = MADI
			LSB / 0	LSB / 0	MIDI remote

	7..38	levelmeter data	MSB / 7		0
			6		Limiter state: 0 = idle, 1 = active
			5	MSB / 2	limiter reduction 000..111
			4	1	limiter reduction
			3	LSB / 0	limiter reduction
			2	MSB / 2	level 000..101 (AD), 000..110 (DA)
			1	1	Level
			LSB / 0	LSB / 0	Level

level steps:	AD	000	-∞
		001	-42
		010	-18
		011	-9
		100	-3
		101	Over
	DA	000	-∞
		001	-54
		010	-36
		011	-18
		100	-9
		101	-3
		110	0

limiter reduction:		000	< -1
		001	> -1
		010	> -3
		011	> -6
		100	> -9
		101	> -12
		110	> -15
		111	> -18

27h	39	fan control	MSB / 7		0
			6	MSB / 1	fan mode: 1 = silent, 2 = cool, 3 = normal
			5	LSB / 0	(fan mode) 0 = n. a.
			4	0	
			3	0	
		(fan speed is response only)	2	MSB / 2	fan speed: 0..5, 0 = off, 5 = full speed,
			1	1	(fan speed) 1..4 = slower..faster
			LSB / 0	LSB / 0	(fan speed)

28h	40	temperature	MSB / 7		0
			6	MSB / 6	temperature in °C, binary value 0..127
			5	5	(temperature)
			4	4	(temperature)
			3	3	(temperature)
			2	2	(temperature)
			1	1	(temperature)
			LSB / 0	LSB / 0	(temperature)

---

## User's Guide



# **M-32 AD**

## **M-16 AD**

### ▶ **Application Examples**

## 20.1 Formats and Number of Channels

PC or Mac based recording and playback can be realized easily with the M-series converters. **ADAT optical** and **MADI** formats are available for data transmission. RME offers several specialized computer interfaces:

- **HDSPe RayDAT:** PCI Express card with 4 optical inputs and outputs in ADAT format (3 channels in and out respectively). Offers an additional SPDIF I/O (RCA) and an AES/EBU I/O (XLR). Internal mixer for free routing and mixing of all I/Os.
- **HDSPe MADI:** PCI Express card with coaxial and optical input and output in MADI format (64 channels each). Offers an additional analog stereo output for monitoring. Internal mixer for free routing and mixing of all I/Os. Also available as PCI version (HDSP MADI).
- **HDSPe MADiface:** PCI ExpressCard for notebooks, with coaxial and optical input and output in MADI format (64 channels each). Internal mixer for free routing and mixing of all I/Os.

	<b>ADAT – HDSPe RayDAT</b>	<b>MADI – HDSPe MADI</b>
<b>General</b>	<ul style="list-style-type: none"> <li>- As ADAT is a common format, many other devices can be connected to the HDSPe RayDAT as well</li> <li>- cost efficient at low channel counts</li> <li>- More than 32 channels require a second HDSPe RayDAT</li> </ul>	<ul style="list-style-type: none"> <li>- Specialized interface for professional users, therefore not available everywhere</li> <li>- cost efficient at high channel counts</li> <li>- More than 64 channels require a second HDSPe MADI</li> </ul>
<b>Comparison</b>	<ul style="list-style-type: none"> <li>- short cables (&lt; 10m)</li> <li>- 8 channels per cable</li> <li>- Connectors not lockable</li> <li>- Serial connection not possible</li> <li>- At 48 kHz 32 channels I/O require a total of 8 cables to the computer</li> </ul>	<ul style="list-style-type: none"> <li>- Very long cables (up to 2 km)</li> <li>- 64 channels per cable</li> <li>- Connectors lockable</li> <li>- Serial connection possible</li> <li>- At 48 kHz 64 channels I/O require a total of 2 cables to the computer</li> </ul>

The M-series is applicable in many different ways, no matter if used with ADAT or MADI. All four converters can be combined freely, realizing different setups, matching your individual application or budget.

The following chapters list some typical setups with special notes on the recommended cabling.



## 20.2 Multichannel Playback

M-16 DA and M-32 DA can be combined freely. Therefore 16, 32, 48, 64 (or multiple thereof) different audio signals can be played back by the computer.

When using the HDSPe RayDAT the converters are connected via ADAT optical with the card. It is recommended to operate the card in clock mode Master, with all converters synchronizing to the ADAT signal (Slave). This setup will allow for up to 32 channels with 2 M-16 DA. The playback is automatically sample-synchronous between the units, as the RayDAT plays all signals on all 4 ports perfectly synchronized. An additional word clock connection between RayDAT and converters is not required.

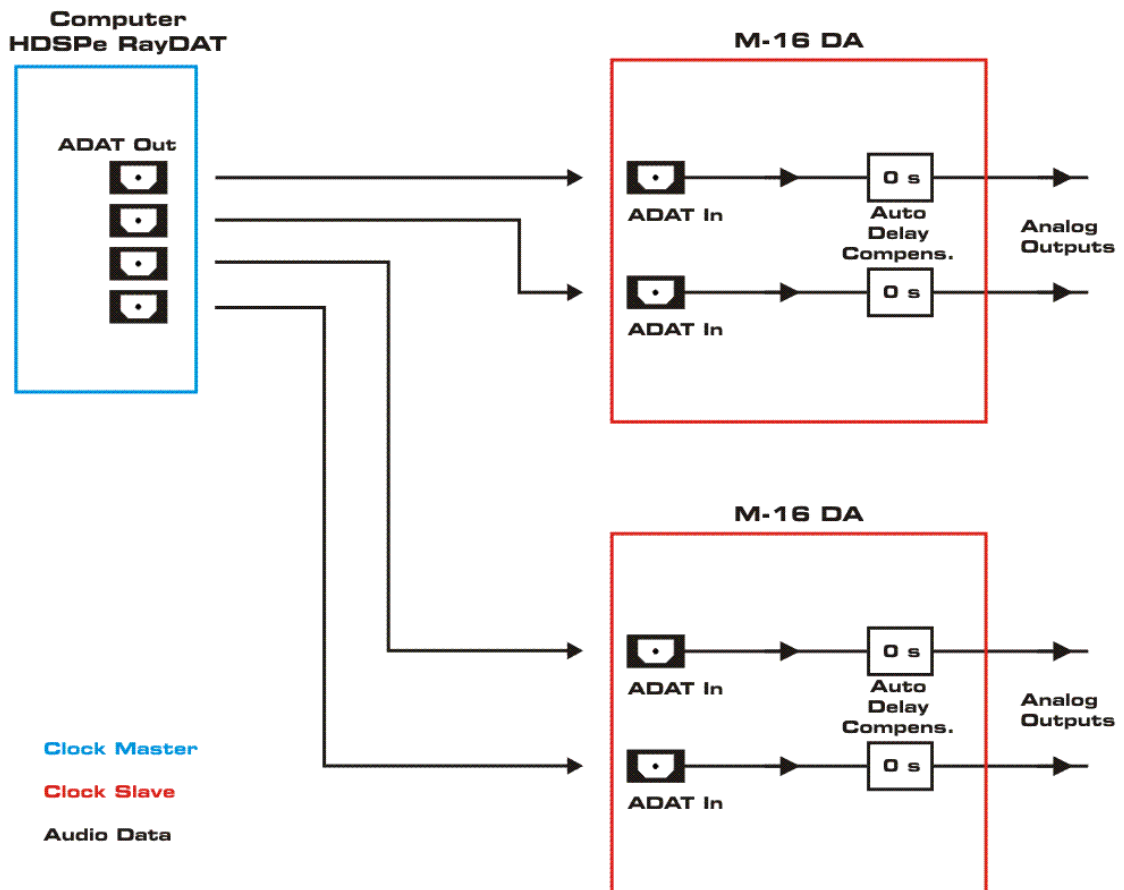

When using the HDSPe MADI the converters and the card are connected serially. RME recommends the usage of optical MADI cables. These provide a useful galvanical separation between the units, and are immune against any kind of electromagnetic interference.

It is recommended to operate the card in clock mode Master, all converters synchronized to the MADI signal (Slave). This setup will allow for up to 64 channels with 4 M-16 DA.

Despite serial cabling the playback is sample-synchronous between all units, because the converters automatically activate *Delay Compensation*. An additional word clock connection between HDSPe MADI and the converters is not required.

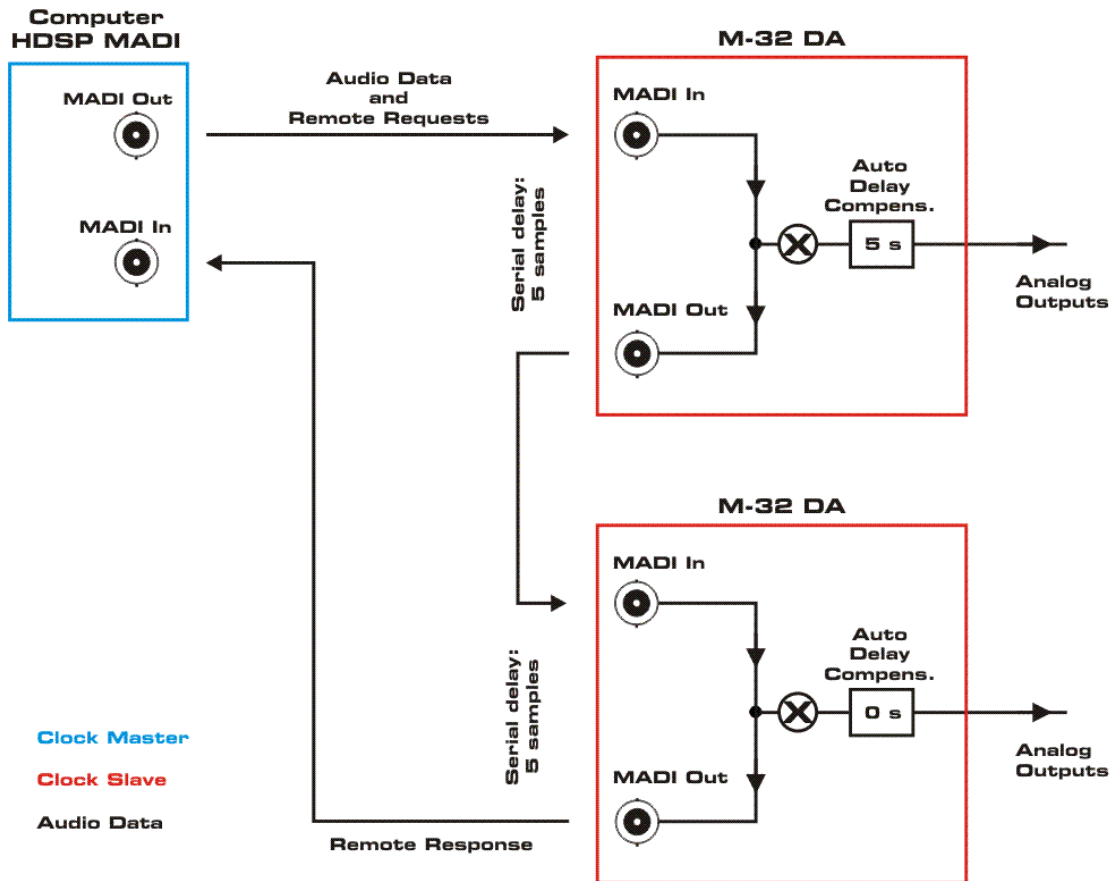

## 20.3 Multichannel Recording

M-16 AD and M-32 AD can be combined freely. Therefore 16, 32, 48, 64 (or multiple thereof) different audio signals can be recorded by the computer.

When using the HDSPe RayDAT, the converters are connected via ADAT optical with the card. This setup will allow for up to 32 channels with 2 M-16 AD.

The clocking can be set up in different ways. It is recommended to operate the card in clock mode Master, with all converters operating as slave.

**One M-16 AD.** The clock source can be an unused ADAT output of the RayDAT. In case the Word Clock Module of the RayDAT is present, its word clock signal can serve as clock source for the converter.

**Two M-16 AD.** As described above, the first converter might use an unused RayDAT ADAT output as its clock source. The word output of the first converter has to be connected to the word input of the second converter, which has to be set to word as clock source. The same applies if the RayDAT's WCM is present, so only one word clock line is required from the card to the converters.

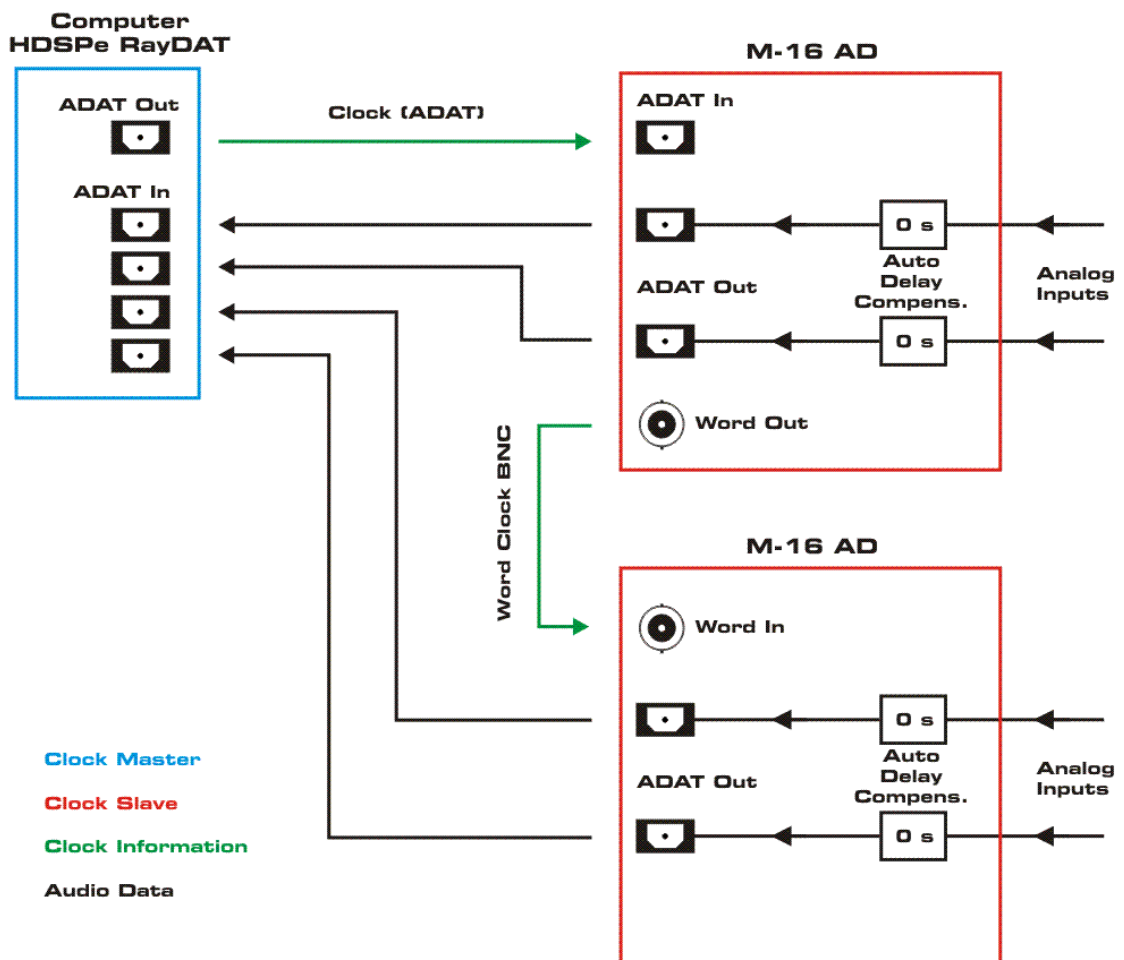

When using the HDSPe MADI the converters and the card are connected serially. RME recommends the usage of optical MADI cables. These provide a useful galvanical separation between the units, and are immune against any kind of electromagnetic interference.

It is recommended to operate the card in clock mode Master, all converters synchronized to the MADI signal (Slave). This setup will allow for up to 64 channels with 4 M-16 AD.

Despite serial cabling the recording is sample-synchronous between all units, because the converters automatically activate *Delay Compensation*. An additional word clock connection between HDSPe MADI and the converters is not required.

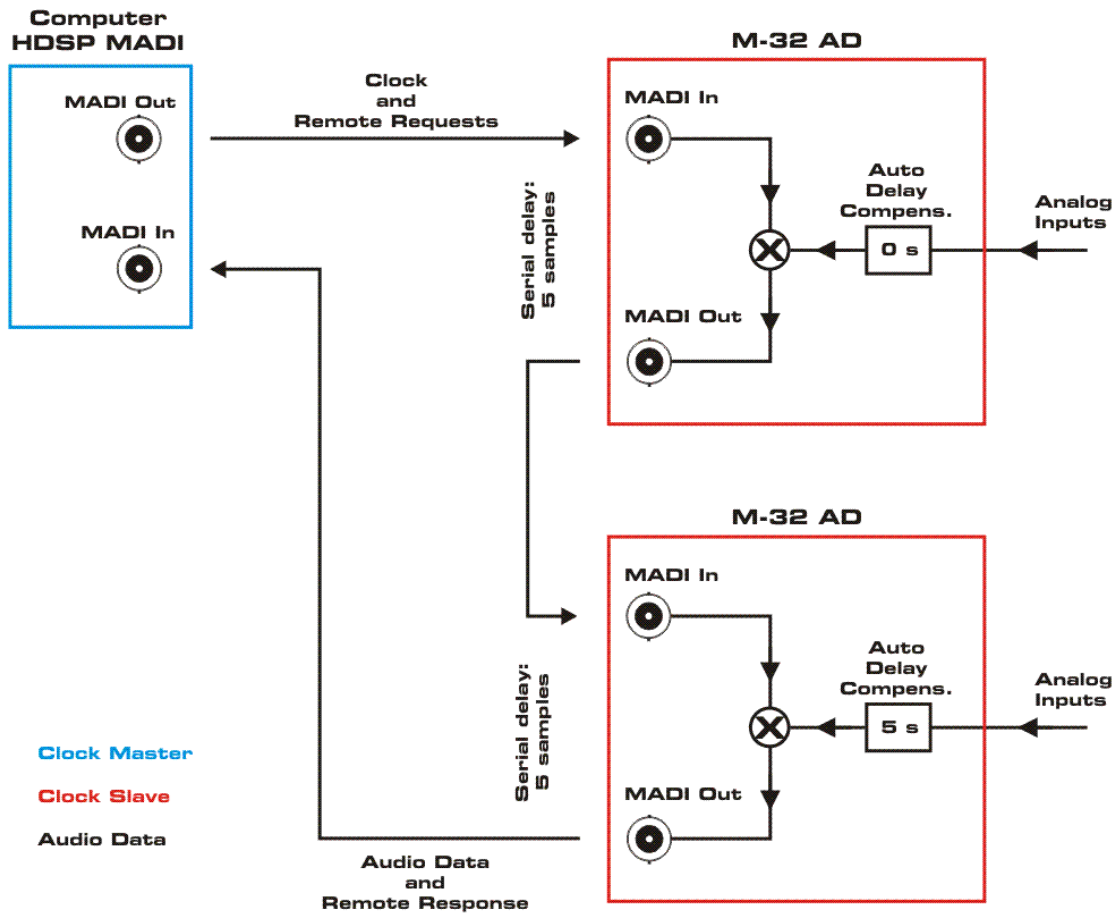

## 20.4 Multichannel Recording and Playback

The converters of the M-series can be combined freely. Therefore 16, 32, 48, 64 different audio signals (or multiple thereof) can be played back and recorded by the computer. Recording and playback do not need to have the same number of channels.

When using the HDSPe RayDAT, the DA converters will simply synchronize to the playback signal via their ADAT input. The AD converters are synchronized by the word output of the DA converter. No WCM is required, and no ADAT port has to be sacrificed. Up to 32 channels of recording and playback are available simultaneously. An additional word clock connection between RayDAT and the converters is not required.

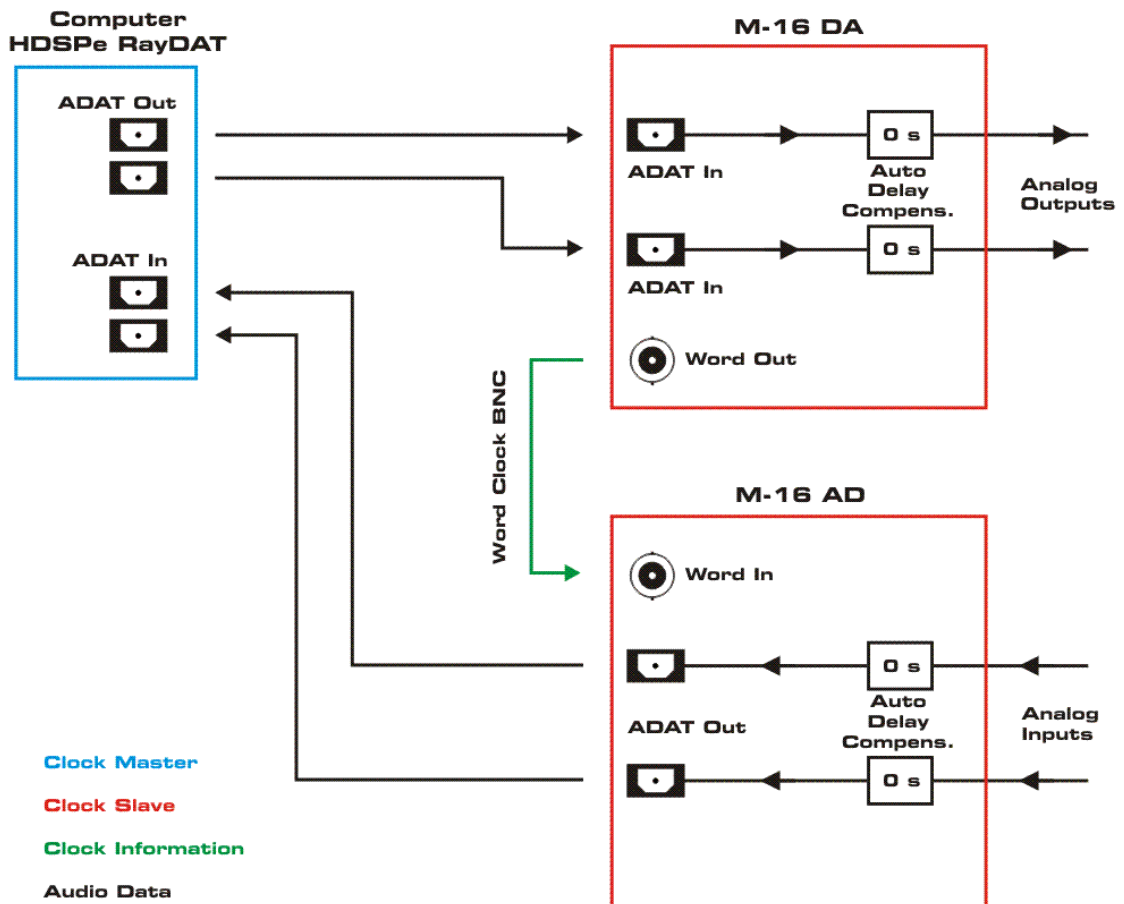

---

When using the HDSPe MADI, the converters and the card are connected serially. RME recommends the usage of optical MADI cables. These provide a useful galvanical separation between the units, and are immune against any kind of electromagnetic interference.

It is recommended to operate the card in clock mode Master, all converters synchronized to the MADI signal (Slave). This setup will allow for up to 64 channels record with 4 M-16 AD and up to 64 channels playback with 4 M-16 DA.

Despite serial cabling the playback is sample-synchronous between all units, because the converters automatically activate *Delay Compensation*. An additional word clock connection between HDSPe MADI and the converters is not required.

Note: The Delay Compensation operates separately for AD and DA converters. It will only work when the AD- and DA-converters are connected serially in an organized way. A DA between two AD (or vice versa) will prevent correct recognition of identical units and subsequently disable the activation of the Delay Compensation.

### **Correct Cabling**

The correct setup of a rack regarding serial cabling is not AD-converters on top and DA-converters at the bottom, but vice versa. If the AD-converters are supposed to remain in top position, one has to get used to a cabling within the rack from bottom to top. This is valid not only for the AD/DA-breakout presented here, but also for the next chapter. The MADI output of the card must be followed by a DA-converter. This becomes easily apparent when using all 64 channels, as a different order will cause some channels to be overwritten with data from other units within the rack.

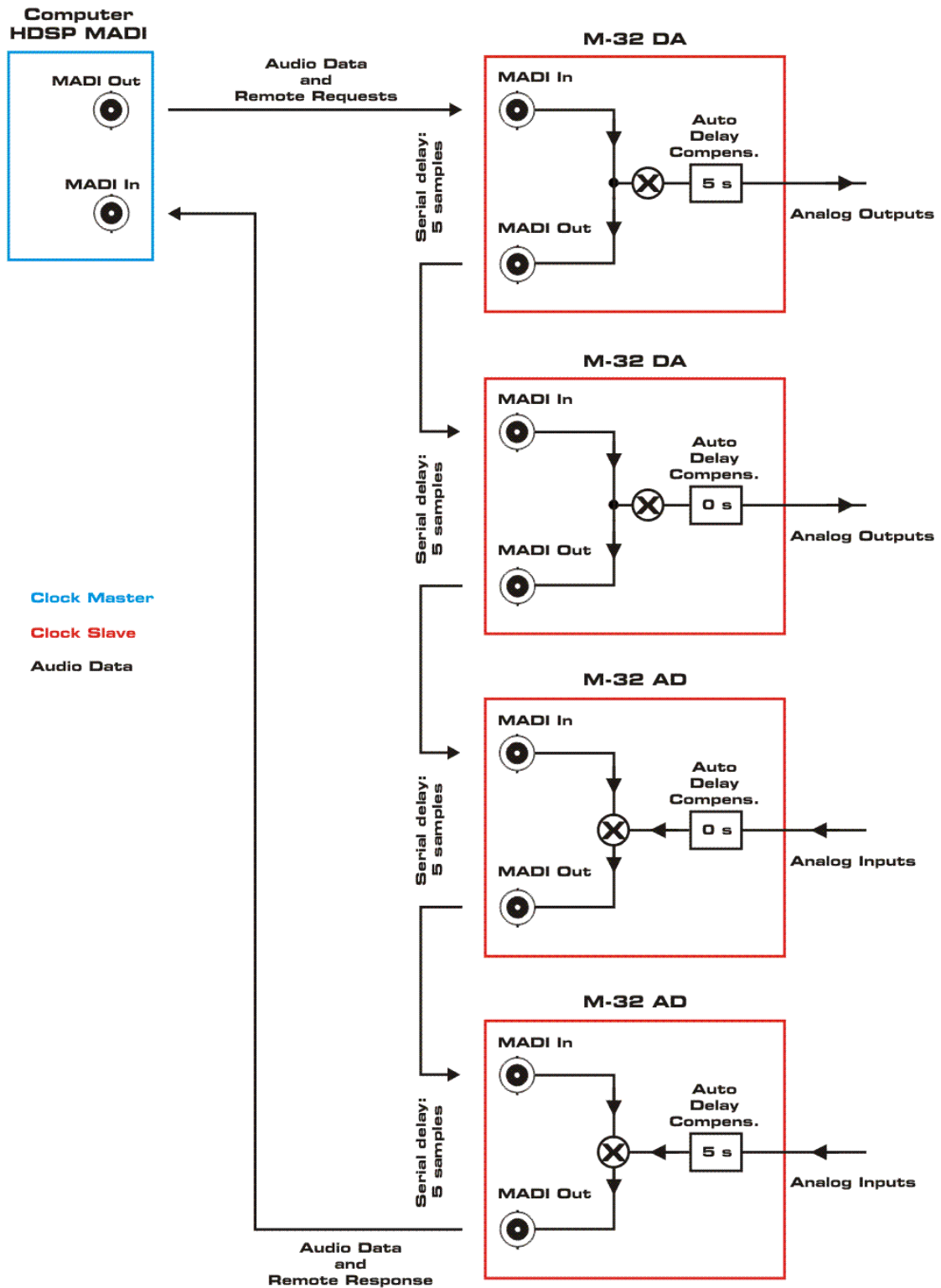

## 20.5 Digital Multicore

Using optical MADI, the converters of the M-series are perfectly suitable as a replacement for an analog Multicore. Such a setup provides several advantages:

- No big and heavy cable drum
- Up to 64 channels bi-directional with just one duplex cable
- Flexible setup
- Transmission of MIDI signals included

Stage and FOH do not need to have the same number of channels. For example while 16 channels are sent to the stage, 64 channels can be sent from the stage to the FOH.

The Multicore consists of a MADI ring connection of all converters. Within the chain one unit is operated with its internal clock, all others are synchronized to their MADI input signal.

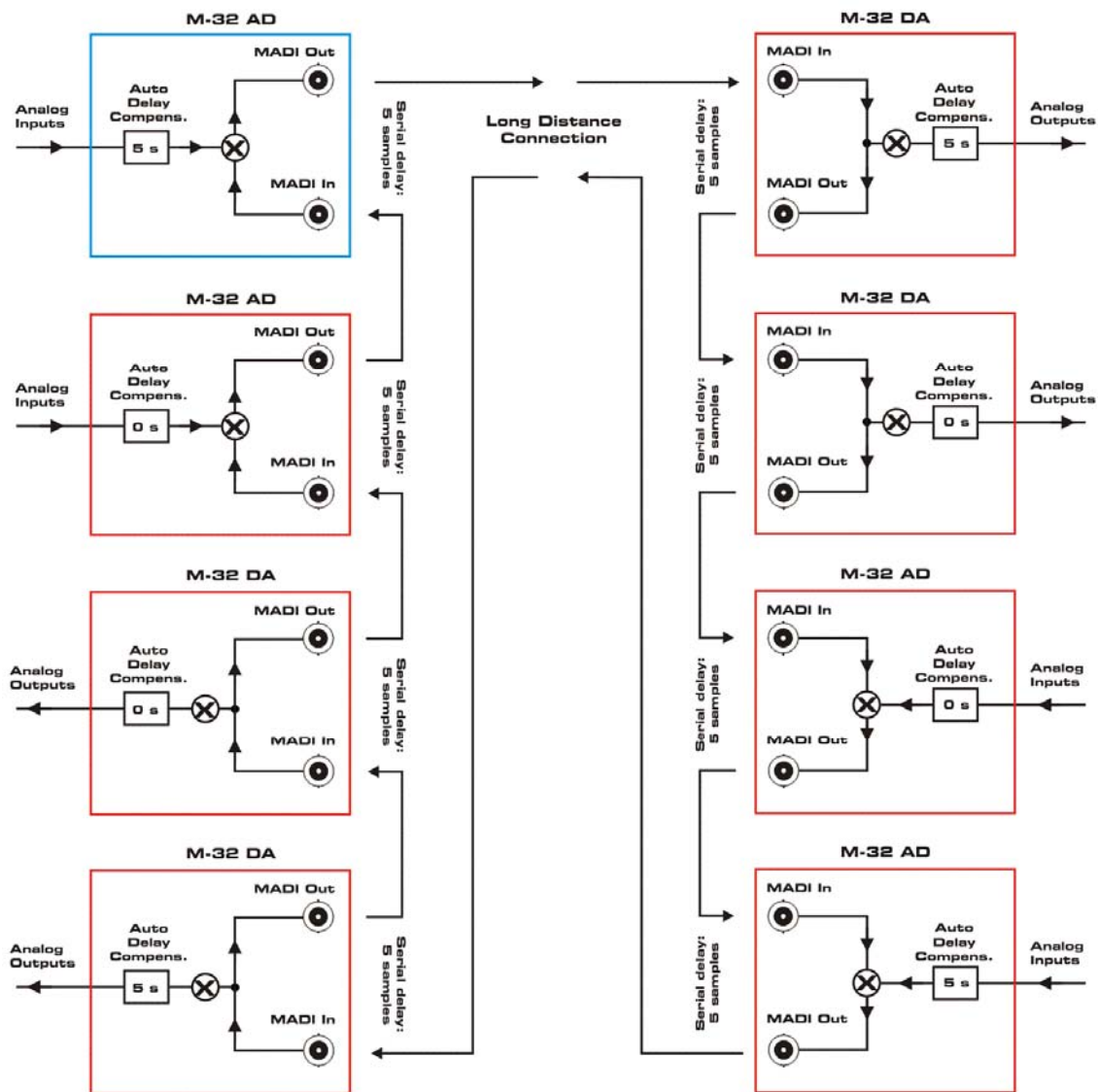



---

Despite serial cabling the playback is sample accurate between all units, because the converters automatically activate *Delay Compensation*.

Note: The Delay Compensation operates separately for AD and DA converters. It will only work when the AD- and DA-converters are connected serially in an ordered way. A DA between two AD (or vice versa) will prevent correct recognition of identical units and subsequently disable the activation of the Delay Compensation.

### **Correct Cabling**

The correct setup of a rack regarding serial cabling is not AD-converters on top and DA-converters at the bottom, but vice versa. If the AD-converters are supposed to remain in top position, one has to get used to a cabling within the rack from bottom to top. This is valid not only for the Multicore presented here, but also for the previous chapter.

One side's AD-converter must be followed by the other sides DA-converter. This becomes easily apparent when using all 64 channels, as a different order will cause some channels to be overwritten with data from other units within the rack.

## **20.6 Multiple Playbacks**

The MADi input of the DA-converters will not only serve as data source for conversion, but also as MADi pass-through input. Since a single M-32 DA or M-16 DA does not convert all 64 channels of the MADi signal, all channels of the input signal are passed to the output. Additional M-32 DA or M-16 DA can be connected serially to convert the remaining signals, in any combination, up to a maximum of 64 channels: One M-32 DA with one or two M-16 DA or up to four M-16 DA.

Unlike the ADs, the DAs perform a complete pass-through. The incoming data is used, but not replaced by another.

Therefore and because MADi covers long distances, the same channels can also be converted in several different (electrically separated) locations, with comfortable and unambiguous front panel channel selection.

The individual choice of a block of 16 or 32 channels to be converted is set on each unit's front plate via the MADi IN key.