



Control[®] 23T

Ultra-Compact
Indoor/Outdoor
Background/Foreground Speaker

Professional Series

Key Features:

- ▶ Isolation transformer for 70.7V/100V distributed-line sound systems.
- ▶ Components: 3½" Polypropylene coated woofer, ½" Titanium coated horn loaded tweeter.
- ▶ Built-in *InvisiBall*[®] mounting hardware*
- ▶ Weather resistant enclosure and transducers
- ▶ Readily paintable to match decor
- ▶ 90° x 90° high frequency horn
- ▶ Overload Protection Circuitry

*Patents pending worldwide



The Control[®] 23T is the most compact of JBL Professional's Control Contractor Series indoor/outdoor loudspeakers making it a perfect choice for patios, foyers, retail or other applications where foreground/background music and paging are required, with minimum aesthetic impact. The Control 23T can be used in either 70.7V or 100V distributed-line sound systems. The single power tap is 5W at 70.7V and 10W at 100V.

The unique *InvisiBall*[®] mounting hardware is included in each system and makes short work of permanent installation. In addition to rapid installation, the *InvisiBall* mounting method adds the benefit of vertical rotation of up to 37° and horizontal rotation of up to 44°. Because *InvisiBall* adjustments are made through a hidden access behind the logo badge, the grill never needs to be removed and there exists a high degree of theft deterrence.

The Control[®] 23T readily accepts a variety of paints and finishes to match any decor.

Weather resistance is maximized by coating the woofer cone in polypropylene and terminating its circumference in JBL's *WeatherEdge*[™], a seamless, rubberized extension of the woofer surround that provides added protection to critical transducer elements. The polycarbonate tweeter diaphragm is reinforced with a thin film of titanium for added rigidity and endurance against sun, salt and moisture. Zinc plated grilles resist rusting.

Available in black (Control 23T) and white (Control 23T-WH).

Specifications:

Frequency Range (-10 dB):	100 Hz to 21 kHz	
Power Capacity:	Components and Network: 50 Watts continuous program ² Transformer: 5W @ 70V, 10W @ 100V (IEC pink noise, 100 hrs.)	
Nominal Coverage:	90° x 90°	
Nominal Output:	70.7V Input 89 dB	100V Input 92 dB
Directivity Factor (Q):	4.8	
Directivity Index (DI):	6.8	
Nominal Impedance:	8 ohms	
Crossover Frequency:	3.5 kHz	
LF Driver:	88 mm (3.5 in) Polypropylene cone w/WeatherEdge	
HF Driver:	13 mm (.5 in) Titanium coated polycarbonate	
Enclosure Material:	HIPS (High Impact Polystyrene)	
Overload Protection:	Full-Range power limiting to protect network and transducers	
Termination:	Spring terminals, accepts banana plug	
Safety Agency Rating:	Transformer UL1876 recognized	
Environmental:	Conforms to Mil Spec 810 for humidity, salt spray, temperature & UV. IEC 529 IP-X4 splashproof rating.	
Dimensions (H x W x D):	193 x 140 x 111 mm (7.6 x 5.5 x 4.4 in)	
Net Weight (ea):	1.8 kg (4 lbs)	
Shipping Weight (pr):	4.1 kg (9 lbs)	
Included Accessories:	InvisiBall Assembly 4 mm x 80 mm hex key	
Optional Accessories:	MTC-23SSG: Stainless Steel Grille. Silver, black (-BK) or White (-WH) MTC-23WMG: Weather Max(tm) Grille with backing to break up driving rain. MTC-23CM: Ceiling-Mount Adapter MTC-23V: For vertical columnar orientation of up to 3 loudspeakers MTC-25/23H: For horizontal splaying of two speakers. Three brackets array up to six loudspeakers in a 360° array.	

¹Half-space (on-wall).

²Continuous program power is a conservative expression of the system's ability to handle normal speech and music program material and is defined as 3 dB above the Continuous Pink Noise Rating (IEC-shaped pink noise with a 6 dB crest factor, for 100 hours continuously).

³Half-space (on-wall), ave 100 Hz to 10 kHz.

JBL continually engages in research related to product improvement. Changes introduced into existing products without notice are an expression of that philosophy.

▶ Control® 23T Ultra-Compact Indoor/Outdoor Background/Foreground Speaker

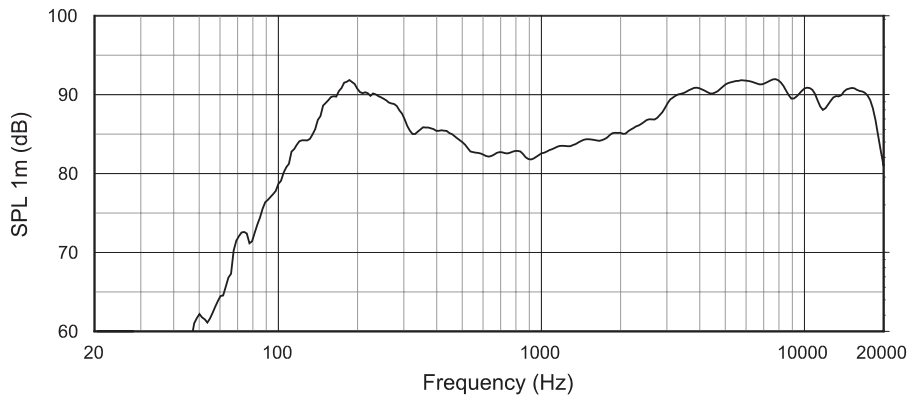

Frequency Response with 70.7V input in half-space (on-wall, 2π). For 100V input, raise curve +3dB.

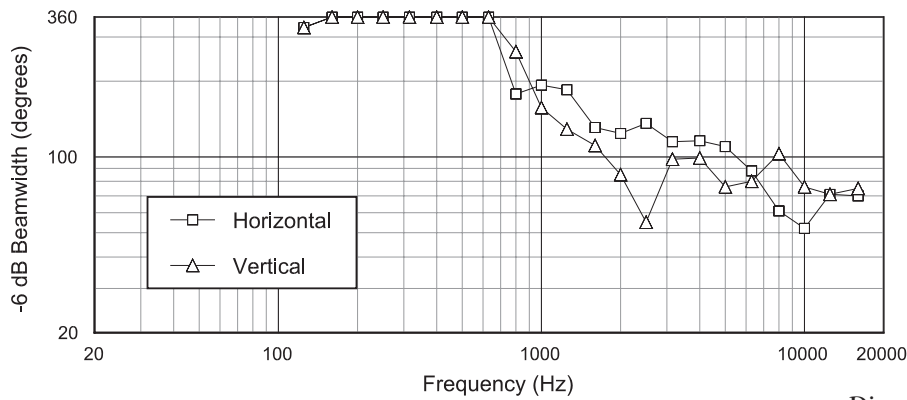

Beamwidth

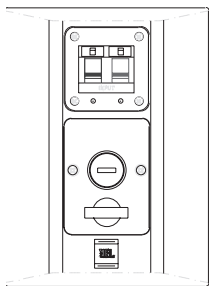

Rear VIEW

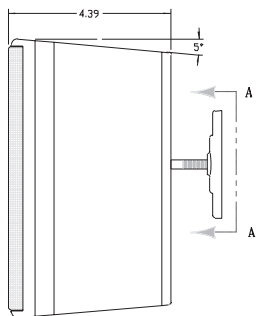

Directivity Index, Q

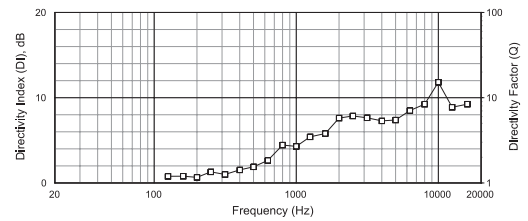

Horizontal Off Axis Frequency Response

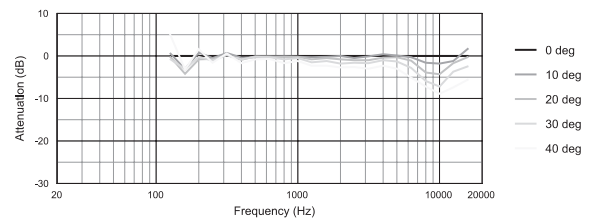

Vertical Off Axis Frequency Response (up)

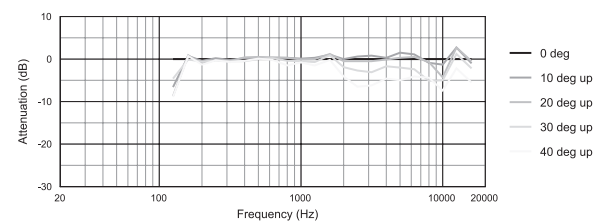

Vertical Off Axis Frequency Response (down)

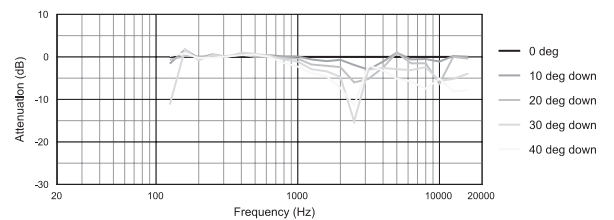

Horizontal 1/3 Octave Polars

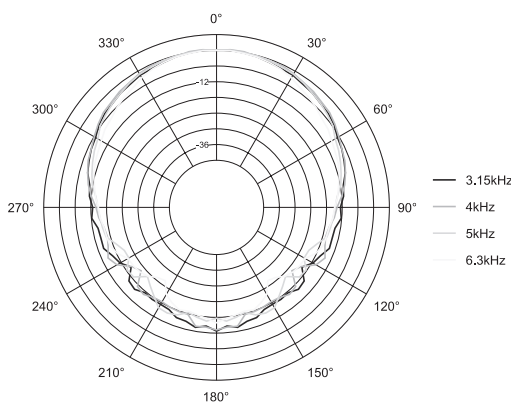
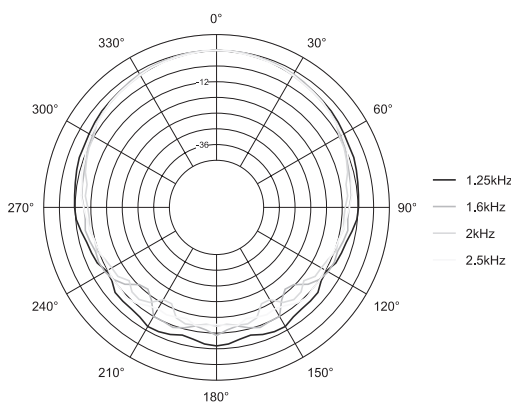
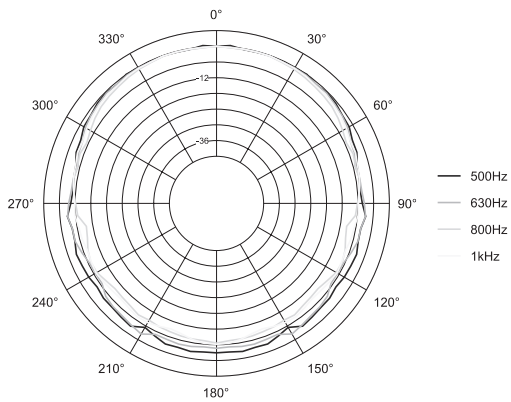
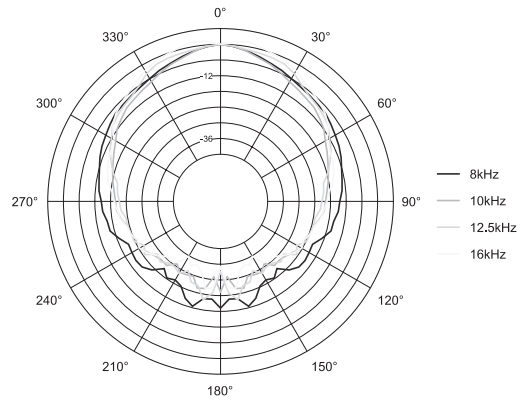
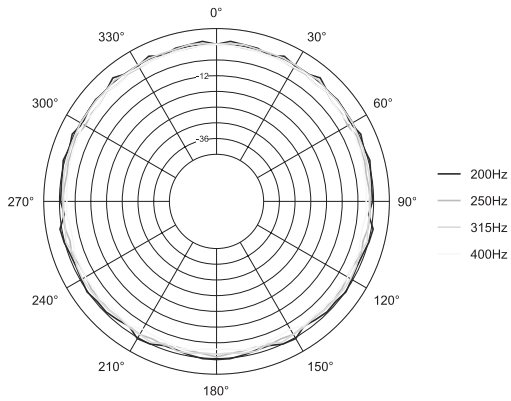

Architectural Specifications:

The loudspeaker shall consist of a 90mm (3-1/2 in) low frequency transducer, 13 mm (1/2 in) high frequency transducer, and frequency dividing network installed in a ported enclosure. The low frequency voice coil shall be 19 mm (3/4 in) in diameter.

Performance specifications of a typical production unit shall be as follows: Usable frequency response shall extend from 100 Hz to 21 kHz (10 dB below rated sensitivity, in half-space, with no external equalization). The loudspeaker shall be equipped with a transformer for use in either 70.7 or 100V distributed-line sound systems. The tap shall be nominally 5W @ 70.7V and 10W @ 100V. The frequency dividing network shall have a crossover frequency of 3.5 kHz. Rated power capacity of the components and network shall be at least 50 watts continuous program power, defined as 3dB above a test signal of filtered random noise conforming to international standard IEC268-5 (shaped pink noise with a peak-to-average ratio of 6dB), for 100 continuous hours duration.

The system shall be protected against damage from occasional overpowering via full range series lamps that limits the power to the network and transducers. The high frequency transducer shall be horn-loaded to more evenly cover a nominal 90° horizontal by 90° vertical area.

The enclosure shall be constructed of high-impact polystyrene for protection against the elements in outdoor applications, and for paintability. The grille shall be completely zinc-coated for resistance against rusting, shall be bake-painted black, and shall be secured via screws to keep it in place when facing downward.

The low frequency transducer shall have a polypropylene cone and a butyl rubber surround which shall extend seamlessly over the edge of the speaker frame for protection against the elements. The high frequency transducer shall be constructed of polycarbonate, reinforced with a titanium film for additional weather resistance. The system shall withstand Mil Spec 810 testing with specified time durations for exposure to the following environments with no effect on its acoustical performance or structural integrity: salt spray (method 509.3), temperature -19°C to 49°C (method 501.3 and 502.3), 95% humidity (method 507.3) and ultra-violet (method 505.3). The system shall have a IEC 529 splashproof rating of IP-X4.

For theft deterrence, the installation access area shall be hidden behind a snap-out cover, and the access area shall be on the front of the loudspeaker for ease of installation and adjustment. The loudspeaker shall be rotatable over a minimum of ±35° in all directions via a ball-type mounting system. The ball mechanism shall be internal to the cabinet to allow low-profile mounting and better stability via a short moment arm. The logo shall be rotatable for proper orientation when the loudspeaker is mounted horizontally or vertically.

The external wiring connectors shall be spring loaded and gold plated, and shall accept bare wire, single or dual banana-type connectors with 19 mm (3/4 in) spacing. Overall cabinet dimensions shall be no greater than 193 mm (7.6 in) high by 140 mm (5.5 in) wide by 111 mm (4.4 in) deep and shall weigh no more than 1.8 kg (4 lbs). The finish shall be a paintable lightly textured black.

The system shall be the JBL Model Control 23T with included Invisiball® mounting system.

▶ Control® 23T Ultra-Compact Indoor/Outdoor Background/Foreground Speaker

Vertical 1/3 Octave Polars

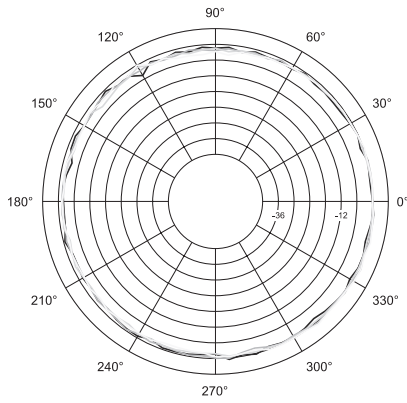

- 200Hz
- 250Hz
- 315Hz
- 400Hz

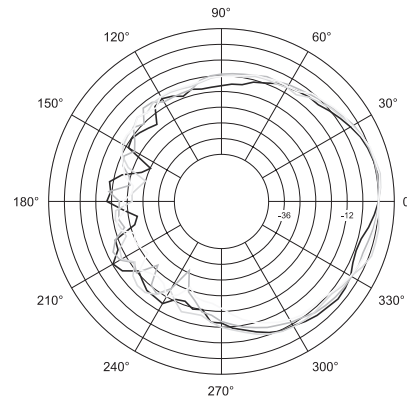

- 3.15kHz
- 4kHz
- 5kHz
- 6.3kHz

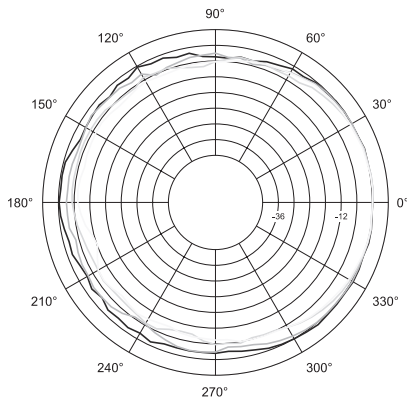

- 500Hz
- 630Hz
- 800Hz
- 1kHz

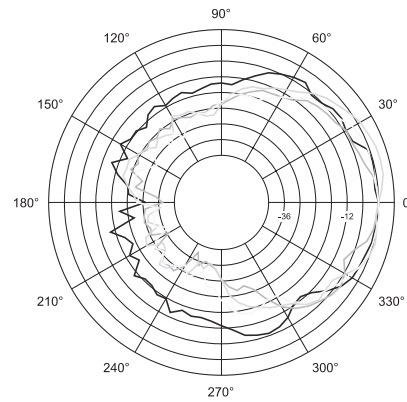

- 8kHz
- 10kHz
- 12.5kHz
- 16kHz

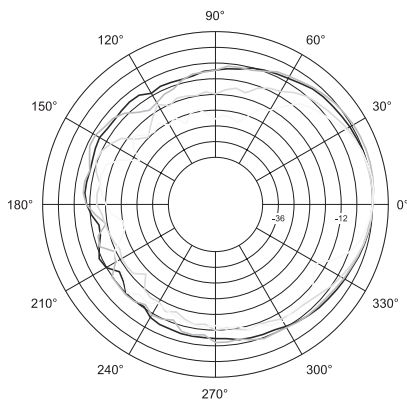

- 1.25kHz
- 1.6kHz
- 2kHz
- 2.5kHz



JBL Professional
 8500 Balboa Boulevard, P.O. Box 2200
 Northridge, California 91329 U.S.A.

■ A Harman International Company
 © Copyright 2009 JBL Professional

SS Control 23T
 CRP
 03/09