



Centraverse Overhead Microphone

The Centraverse CVO is a professional low-profile electret condenser microphone designed for overhead sound reinforcement applications. An integrated wire aiming hanger is included for optimal placement above choirs and other ensembles with minimal effort.

Features

- Cardioid pickup pattern
- CommsShield® technology guards against unwanted RF interference from portable wireless devices (smartphones, etc.)
- Superior Shure design and rugged, dependable construction
- Attached 25 ft XLR cable
- Included snap-fit windscreen

Model Variations

CVO-B/C: Cardioid, black
CVO-W/C: Cardioid, white

Note: Model availability depends on region. See your local Shure dealer or distributor for details.

Installation

1. Attach the wire hanger:
 - Snap the wire into the groove on the microphone body.
 - Guide the cable through the spiral at the end of the wire, beginning at the bottom and working toward the exit.
2. Hang the microphone according to the guidelines for placement.
3. Aim the microphone toward the sound source by holding the wire hanger in place and twisting the microphone body.
4. If necessary, tie a strong transparent thread or fishing line to the loop at the end of the wire hanger and attach it to a ceiling anchor for additional stability.
5. Connect the XLR cable to a mixer or P.A. system.

Note: This microphone requires +48V phantom power to operate.

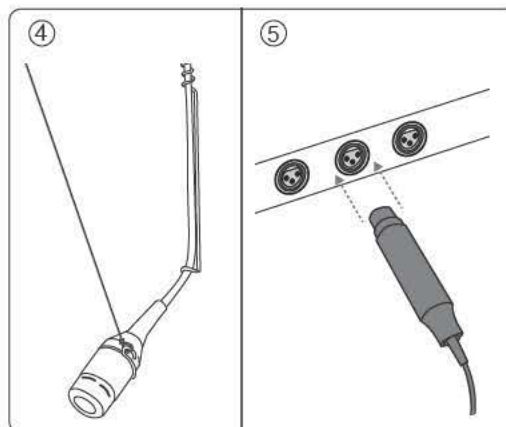
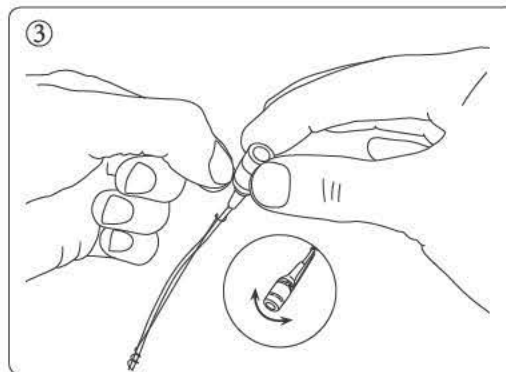
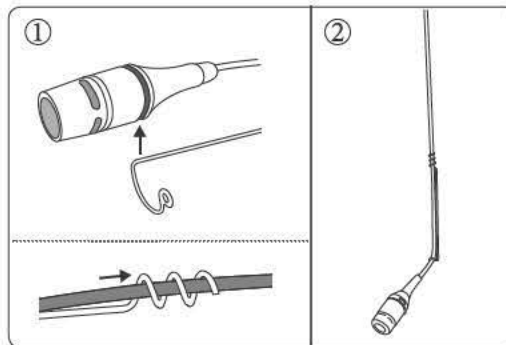

Microphone Placement and Use

1. **3:1 Rule:** If using multiple Shure Centraverse overhead microphones, the distance between the microphones should be three times greater than the distance between the microphone and the sound source.
2. **Choir Installations:** Place the microphone in front of the choir, above their heads and aimed at the back row.
3. **Windscreen:** Use the supplied snap-fit windscreen to eliminate wind noise and plosives. To install the windscreen, snap it into the first groove on the microphone head. To remove the windscreen, locate the gap in the ring and use your fingernail to pull the windscreen off from the right-hand side.

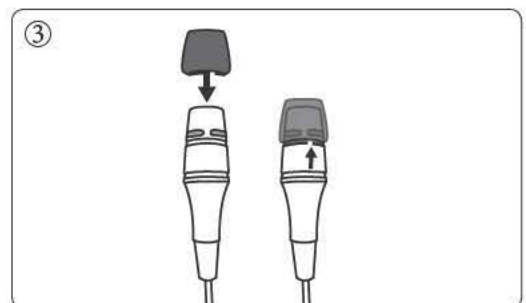
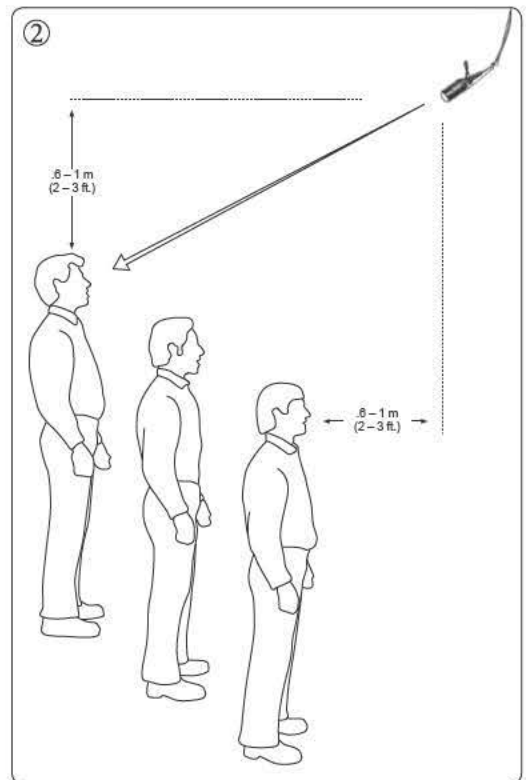
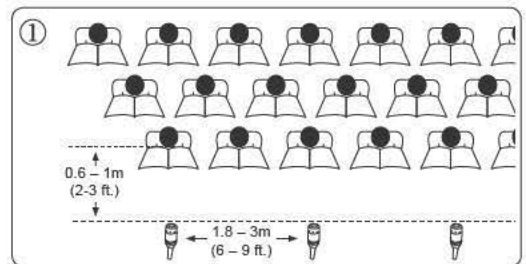

Specifications

Cartridge Type

Electret Condenser

Polar Pattern

Cardioid

Frequency Response

70–16000 Hz

Output Impedance

180 Ω

Sensitivity

open circuit voltage, @ 1 kHz, typical
–33 dBV/Pa[1] (22 mV)

Maximum SPL[2]

1 kHz at 1% THD
120 dB SPL

Signal-to-Noise Ratio[3]

Ref. 94 dB SPL at 1 kHz
67 dB

Dynamic Range

93 dB

Self Noise

equivalent SPL, A-weighted, typical
27 dB SPL

Preamplifier Output Clipping Level

@ 1 kHz, at 1% THD
–7 dBV

Common Mode Rejection

10 Hz to 100 kHz
>45 dB

Polarity

Positive pressure on diaphragm produces positive voltage on pin 2 with respect to pin 3

Environmental Conditions

| | |
|-----------------------|----------------------------|
| Operating Temperature | –18 to 57°C (0 to 135°F) |
| Storage Temperature | –29 to 74°C (–20 to 165°F) |
| Relative Humidity | 0 to 95% |

Power Requirements

11–52 V DC[4], 2.0 mA

Weight

4.7 oz. (133 g)

- [1] 1 Pa=94 dB SPL
[2] THD of microphone preamplifier when applied input signal level is equivalent to cartridge output at specified SPL
[3] S/N ratio is the difference between 94 dB SPL and equivalent SPL of self noise, A-weighted
[4] All specifications measured with a 48 Vdc phantom power supply. The microphone operates at lower voltages, but with slightly decreased headroom and sensitivity.

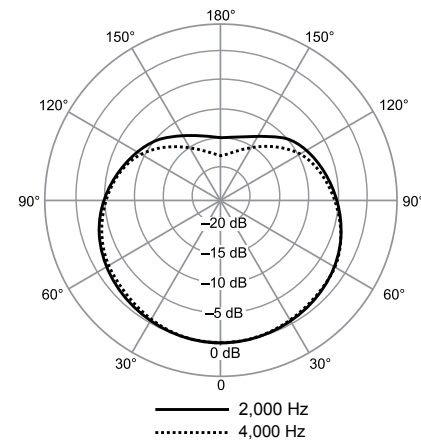
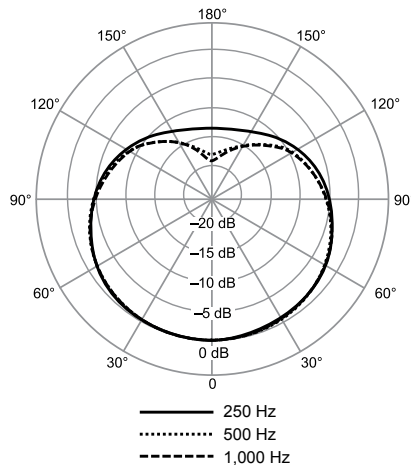
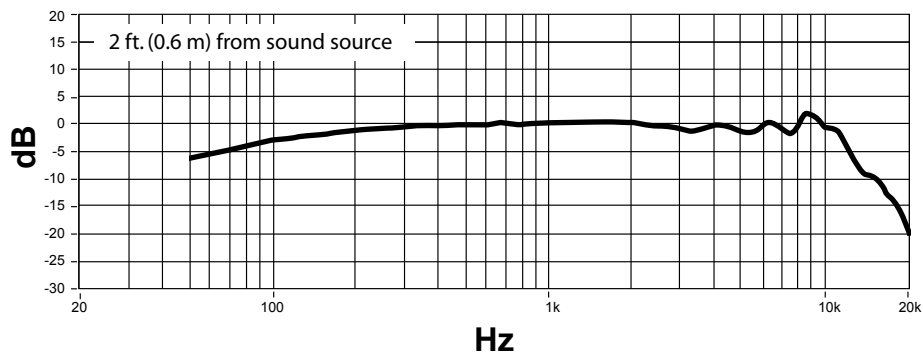

Accessories

Furnished Accessories

| | |
|----------------------------|----------|
| Wire aiming hanger (Black) | 44A16928 |
| Wire aiming hanger (White) | 44B16928 |
| Windscreen (Black) | 95A20541 |
| Windscreen (White) | 95B20541 |

Optional Accessories

| | |
|----------------------------|-----------|
| Windscreen (Black, 4-pack) | ACVO4WS-B |
| Windscreen (White, 4-pack) | ACVO4WS-W |

Certifications

Meets essential requirements of all applicable European Directives.

Eligible for CE marking.

The CE Declaration of Conformity can be obtained from Shure Incorporated or any of its European representatives. For contact information please visit www.shure.com

The CE Declaration of Conformity can be obtained from: www.shure.com/europe/compliance

Authorized European representative:
Shure Europe GmbH
Headquarters Europe, Middle East & Africa
Department: EMEA Approval
Jakob-Dieffenbacher-Str. 12
75031 Eppingen, Germany
Phone: 49-7262-92 49 0
Fax: 49-7262-92 49 11 4
Email: EMEAsupport@shure.de

SHURE®

SHURE Incorporated <http://www.shure.com>
United States, Canada, Latin America, Caribbean:
5800 W. Touhy Avenue, Niles, IL 60714-4608, U.S.A.
Phone: 847-600-2000 U.S. Fax: 847-600-1212 Int'l Fax: 847-600-6446
Europe, Middle East, Africa:
Shure Europe GmbH, Phone: 49-7262-92490 Fax: 49-7262-9249114
Asia, Pacific:
Shure Asia Limited, Phone: 852-2893-4290 Fax: 852-2893-4055