

**OWNER MANUAL
MANUALE D'USO
BEDIENUNGSANLEITUNG**

**MQ100L
MQ100L-W**

- WALL-MOUNTED COLUMN
LOUDSPEAKER
- COLONNA SONORA PER
INSTALLAZIONE A PARETE
- TONSÄULE ZUR WANDMONTAGE



**IMPORTANT NOTES**

Before connecting and using this product, please read this instruction manual carefully and keep it on hand for future reference. This manual is to be considered an integral part of this product and must accompany it when it changes ownership as a reference for correct installation and use as well as for the safety precautions. RCF S.p.A. will not assume any responsibility for the incorrect installation and / or use of this product.

WARNING: To prevent the risk of fire or electric shock, never expose this loudspeaker to rain or humidity and also protect it from dust.

SAFETY AND OPERATING PRECAUTIONS

1. All the precautions, in particular the safety ones, must be read with special attention, as they provide important information.
2. Loudspeaker lines (amplifier outputs) can have a sufficiently high voltage (i.e. 100-70 V) to involve a risk of electrocution: never install or connect this loudspeaker when the line is alive.
3. Make sure all connections have been made correctly and the loudspeaker input voltage (in a constant voltage system) or its impedance is suitable for the amplifier output.
4. Protect loudspeaker lines from damage; make sure they are positioned in a way that they cannot be stepped on or crushed by objects.
5. Make sure that no objects or liquids can get into this product, as this may cause a short circuit.
6. Never attempt to carry out any operations, modifications or repairs that are not expressly described in this manual.
Contact your authorized service centre or qualified personnel should any of the following occur:
The loudspeaker does not function (or works in an anomalous way).
The cable has been damaged.
Objects or liquids have got into the unit.
The loudspeaker has been damaged due to heavy impacts or fire.
7. Should the loudspeaker emit any strange odours or smoke, remove it from the line after having immediately switched the amplifier off.
8. Do not connect this product to any equipment or accessories not foreseen.
For suspended installation, only use the dedicated anchoring points and do not try to hang this loudspeaker by using elements that are unsuitable or not specific for this purpose. Also check the suitability of the support surface to which the product is anchored (wall, ceiling, structure, etc.), and the components used for attachment (screw anchors, screws, brackets not supplied by RCF etc.), which must guarantee the security of the system / installation over time, also considering, for example, the mechanical vibrations normally generated by transducers.
9. **RCF S.p.A.** strongly recommends this product is only installed by professional qualified installers (or specialised firms) who can ensure a correct installation and certify it according to the regulations in force.
The entire audio system must comply with the current standards and regulations regarding electrical systems.
10. There are numerous mechanical and electrical factors to be considered when installing a professional audio system (in addition to those which are strictly acoustic, such as sound pressure, angles of coverage, frequency response, etc.).

IMPORTANT NOTES**WARNING**

11. Hearing loss

Exposure to high sound levels can cause permanent hearing loss. The acoustic pressure level that leads to hearing loss is different from person to person and depends on the duration of exposure.

To prevent potentially dangerous exposure to high levels of acoustic pressure, anyone who is exposed to these levels should use adequate protection devices.

When a transducer capable of producing high sound levels is being used, it is necessary to wear ear plugs or protective earphones.

See the technical specifications in the instruction manual for the maximum sound pressure the loudspeaker is capable of producing.

12. To ensure a correct sound reproduction, loudspeaker phase is to be respected (loudspeakers are connected respecting the amplifier polarity). This is important when loudspeakers are installed adjacent one another, for instance, in the same room.

13. To prevent inductive effects from causing hum, noise and a bad system working, loudspeaker lines should not be laid together with other electric cables (mains), microphone or line level signal cables connected to amplifier inputs.

14. The loudspeaker cable shall have wires with a suitable section (twisted, if possible, to reduce inductive effects due to surrounding electro-magnetic fields) and a sufficient electrical insulation. Refer to local regulations since there may be additional requirements about cable characteristics.

15. Install this loudspeaker far from any heat source.

16. When connect to its low impedance input, do not overload the loudspeaker with too much power.

17. Do not use solvents, alcohol, benzene or other volatile substances for cleaning the external parts of this product.

RCF S.P.A. THANKS YOU FOR PURCHASING THIS PRODUCT, WHICH HAS BEEN DESIGNED TO GUARANTEE RELIABILITY AND HIGH PERFORMANCES.

DESCRIPTION



MQ 100L (/ MQ 100L-W) is a 3 way column loudspeaker providing natural hi-fidelity sound of both speech (to improve the intelligibility) and music, suitable for sound system having fixed loudspeakers where the environment is acoustically critical or there are architectural constraints.

The wide horizontal coverage angle (180°) and the 60° vertical dispersion allow the correct sound reproduction in a wide space, in order to limit feedbacks and improve the sound directivity (important in halls having a long reverberation time).

THE 60° VERTICAL DISPERSION IS ASYMMETRIC: IT IS THE DIFFERENCE BETWEEN 20° UPWARDS AND 40° DOWNWARDS. THE VERTICAL DISPERSION AXIS IS IN FACT ALREADY ANGLED 10° DOWNWARDS, MAKING IT UNNECESSARY TO TILT THE SOUND COLUMN EXCESSIVELY.



MQ 100L IS EQUIPPED WITH:

- 4 rubber surround 3.5" woofers
- 2 cloth coated 0.75" dome tweeters.

Mounting accessories are included. These have been studied to keep the column as close as possible to the wall and simplify its installation. Its tilt angle can be chosen among 0° – 5° – 10°.

It includes a transformer inside for the connection to (100 – 70 V) constant voltage lines, yet it can also be set to 16 Ω (low impedance connection).

The power / mode selection is made by means of the rear panel rotary switch.

LOUDSPEAKER RMS POWER IS:

- | | |
|---|---|
| <p>a. 40 – 20 – 10 – 5 W (selectable), if connected to a 100 V constant voltage line.</p> | <p>b. 20 – 10 – 5 – 2.5 W (selectable), if connected to a 70 V constant voltage line.</p> |
| | <p>c. Max. 60 W on low impedance (16 Ω).</p> |

Its body is made of self-extinguishing (HB level) high density polystyrene.

AVAILABLE IN 2 COLOURS:

- Black MQ 100L
- White MQ 100L –W.

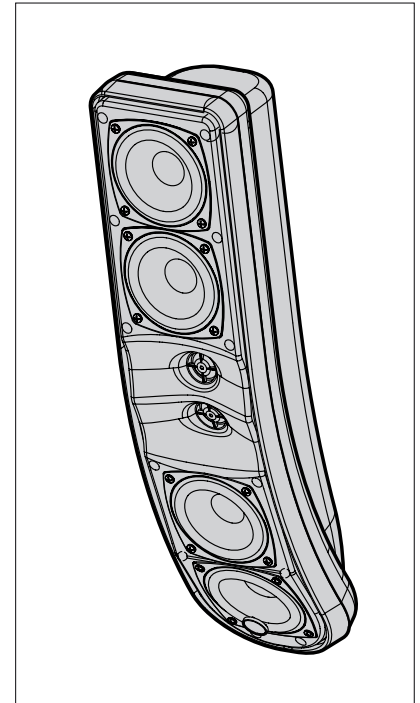

SETTING (REAR PANEL ROTARY SWITCH)



Use a screwdriver to select.

OFF position: the loudspeaker is disabled (muted).

- | | |
|--|---|
| <p>a. 100 V (/ 70 V) constant voltage line
Select the desired power (referred to a 100 V line) among 5 – 10 – 20 – 40 W.
When using a 70 V line, the power is halved: 2.5 – 5 – 10 – 20 W.</p> | <p>b. Low impedance input
Set the rotary switch to the 16 Ω position.</p> |
|--|---|

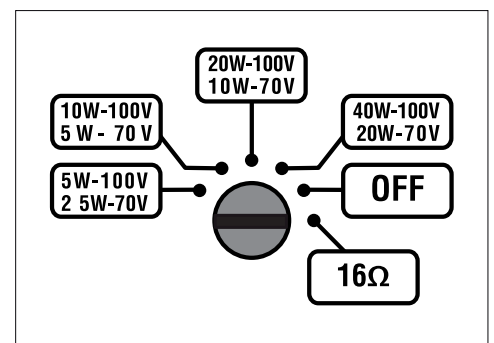

WARNING: NEVER SET THE 16 Ω POSITION WHEN THE LOUDSPEAKER IS CONNECTED TO A 100 / 70 V CONSTANT VOLTAGE LINE.





Loudspeakers are to be installed by qualified personnel, respecting all safety standards. Loudspeakers are to be installed securely.

Make sure the supporting structure (i.e. wall, plasterboards, wood panels, etc.) has the necessary mechanical characteristics for the loudspeaker weight, without the risk of a fall that could damage things or cause an injury.

- a. Fix (vertically) the support to the wall with four M4 dowels and also an end of the safety steel wire through the dowel in the top left-hand corner (picture 1).

THE CONNECTING CABLE (IF INSIDE A FLUSH-MOUNTED PIPE) CAN PASS THROUGH THE WALL-MOUNTED SUPPORT BOTTOM CENTRAL HOLE.



- b. The mounting bracket is available in 3 different measures to choose the sound column vertical tilt angle (picture 2a):
- short, no tilt angle (0°)
 - medium, tilt angle fixed to 5°
 - long, tilt angle fixed to 10°.

PICTURE 1

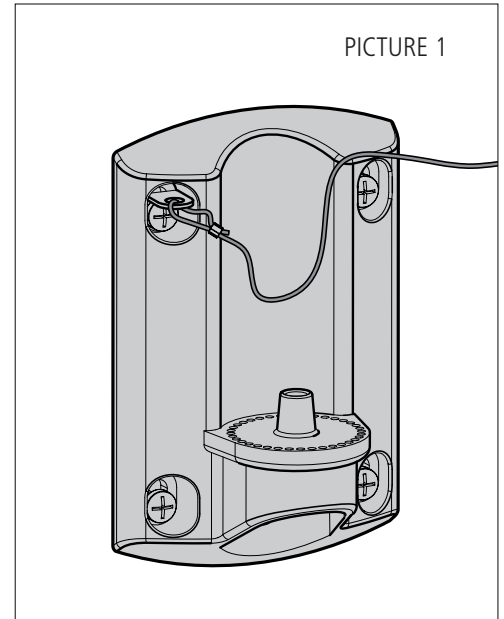

PICTURE 2a

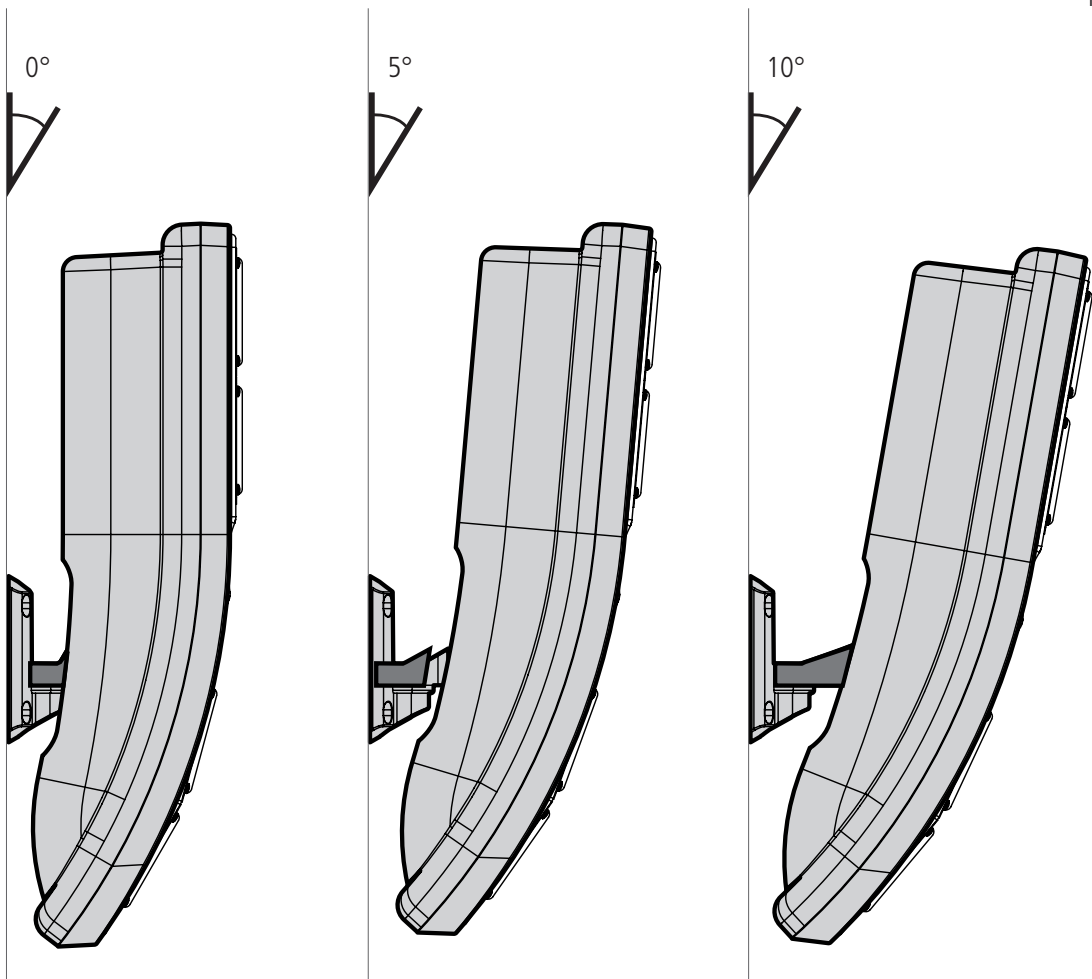

Pictures 2b and 2c: indicative examples of coverage according to the vertical tilt of the sound column, which its centre is fixed at 2 m / 2.5 m over the floor.

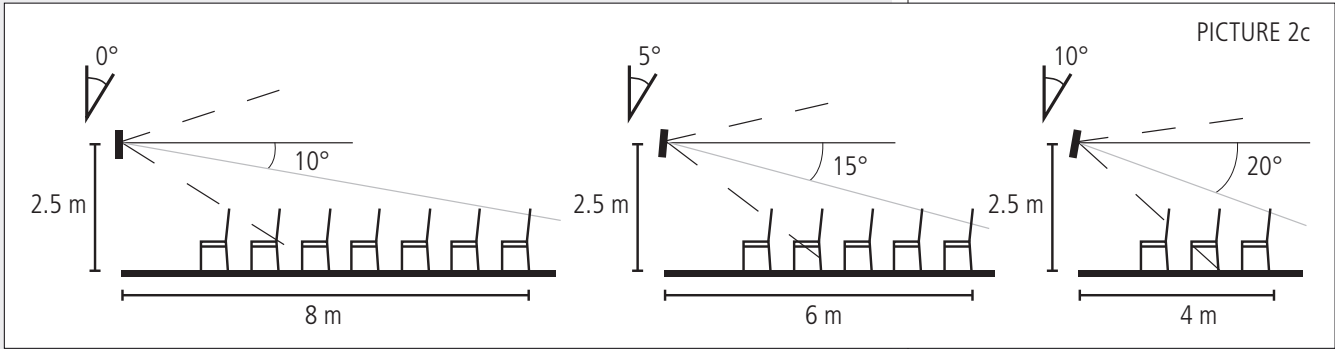
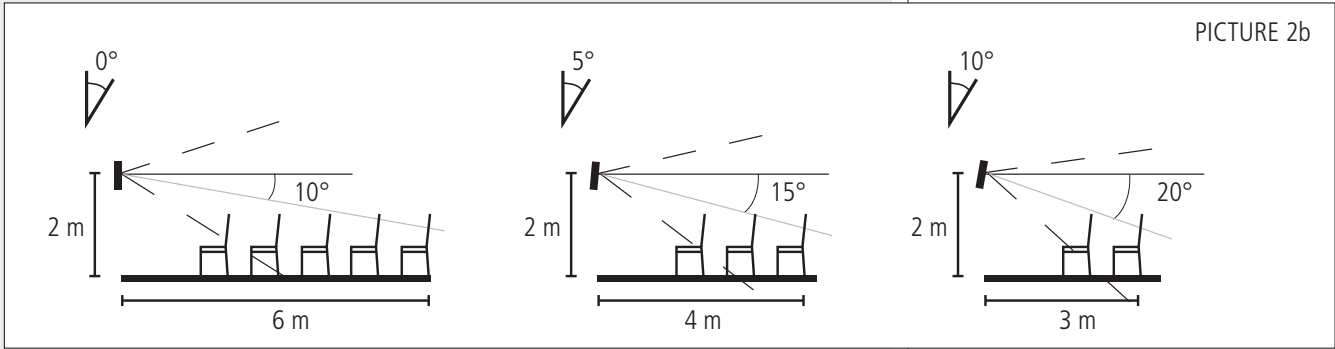

- WITHOUT ANY SOUND COLUMN TILT (0°), THE VERTICAL DISPERSION AXIS ANGLE IS 10° DOWNWARDS.
- IF THE SOUND COLUMN TILT ANGLE IS 5°, THE VERTICAL DISPERSION AXIS ANGLE IS 15° DOWNWARDS.
- IF THE SOUND COLUMN TILT ANGLE IS 10°, THE VERTICAL DISPERSION AXIS ANGLE IS 20° DOWNWARDS.



Choose the most suitable mounting bracket and fix it (in the proper way) to the sound column rear panel (picture 3a) through the 4 self-tapping screws (included). Fix the other end of the safety steel wire through the self-tapping screw in the top right-hand corner (picture 3b) of the bracket.

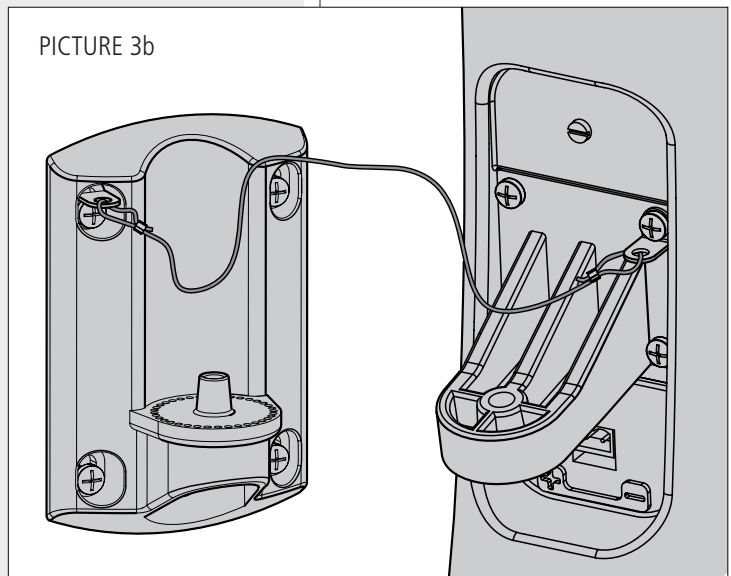
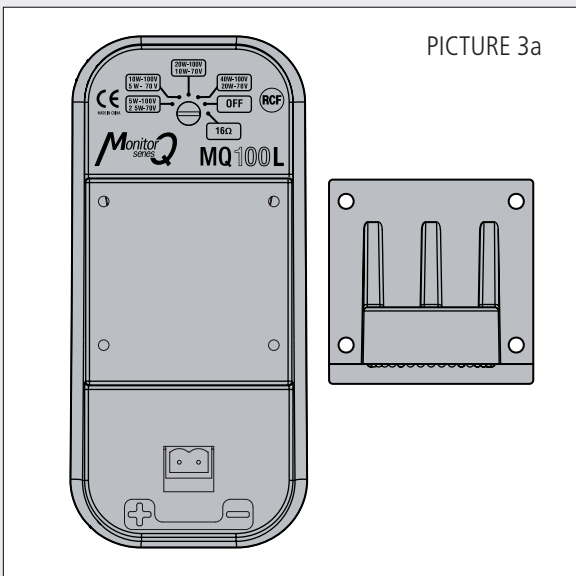

- c. Put the sound column on the wall-mount support (through the bracket), aim it (horizontally) and fix it by tightening the central screw (picture 4).

PICTURE 4

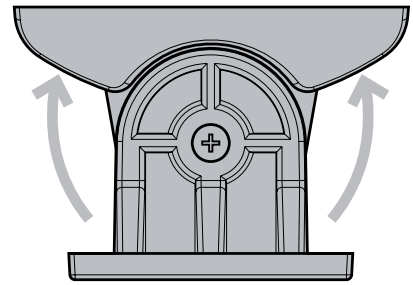

CONNECTION

WARNING: loudspeaker connections should be only made by qualified and experienced personnel having the technical know-how or sufficient specific instructions (to ensure that connections are made correctly) in order to prevent any electrical danger.



To prevent any risk of electric shock, do not connect loudspeakers when the amplifier is switched on. Before turning the system on, check all connections and make sure there are no accidental short circuits. The entire sound system shall be designed and installed in compliance with the current local laws and regulations regarding electrical systems.

The input connector is on the column rear panel (picture 5).

Connect the line positive wire (coming from the amplifier output usually marked '100 V', '70 V', '+' or 'a') to the '+' loudspeaker terminal.

Connect the line negative wire (coming from the amplifier output usually marked '0', '-', 'COM' or 'b') to the '-' loudspeaker terminal.

PICTURE 5

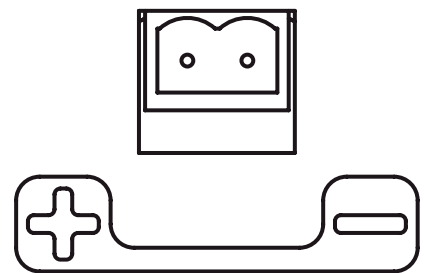

NOTES ABOUT CONSTANT VOLTAGE SYSTEMS



- The loudspeaker input voltage (V_d) shall correspond to the amplifier output voltage (V_a).
- The sum of nominal power values ($P_d \times n$) of all loudspeakers connected to the line shall not exceed the amplifier power (P_a).
- Make sure all loudspeakers are connected in phase to ensure a correct sound reproduction.

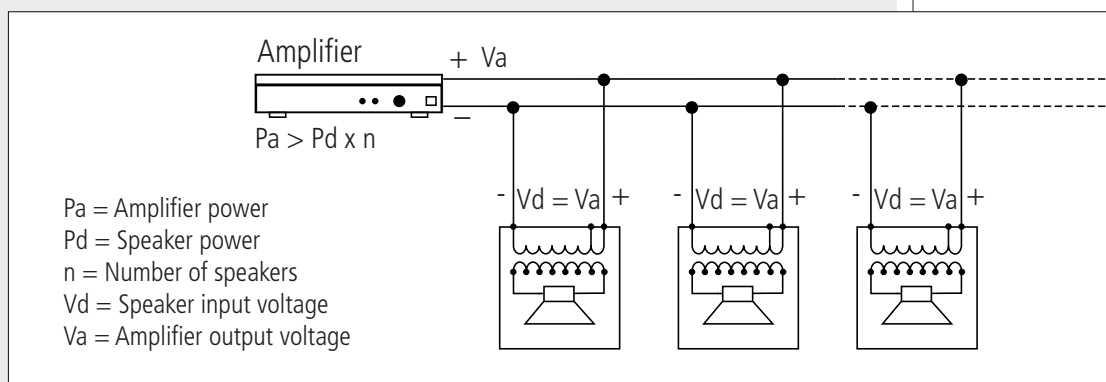

NOTES ABOUT LOW IMPEDANCE CONNECTIONS



- The total loudspeaker impedance must not be lower than the amplifier output impedance.
NOTE: A LOUDSPEAKER TOTAL IMPEDANCE EQUAL TO THE AMPLIFIER OUTPUT ONE PERMITS TO GET THE MAXIMUM DELIVERABLE POWER (BUT AN HIGHER LOUDSPEAKER IMPEDANCE ENTAILS LESS POWER).
- The total loudspeaker power shall be adequate for the maximum deliverable power of the amplifier.
- The loudspeaker line shall be as short as possible (for long distances, it may be necessary to use cables with large cross-section wires).

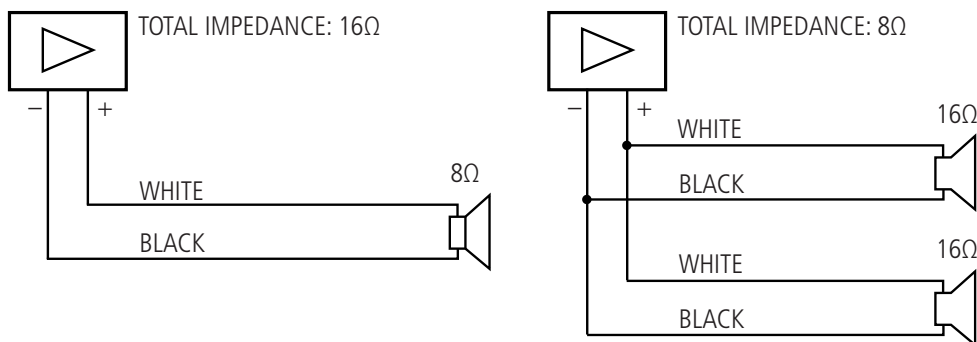

ADDITIONAL NOTES



- Always use cables having wires with an adequate cross-section, considering the cable length and the total loudspeaker power.
- Loudspeaker lines must be kept separated from mains cable, microphone cables or others, in order to avoid inductive phenomena may cause hum or noises.
- Use loudspeaker cables having twisted wires to reduce hum caused by inductive effects due to coupling with electromagnetic fields.
- **NEVER set the rotary switch to the 16 Ω position when the loudspeaker is connected to a (100 – 70 V) constant voltage line.**



TYPE	3 way sound column
TRANSDUCERS	- 4 x rubber surround 3.5" woofer - 2 cloth coated 0.75" dome tweeters
SENSITIVITY	93 dB (1 W, 1 m)
MAX. SOUND PRESSURE LEVEL (MUSICAL POWER)	112 dB (80 W, 1 m)
FREQUENCY RESPONSE (-10 dB)	130 Hz ÷ 20 kHz
RMS POWER	- 40 – 20 – 10 – 5 W (100 V) - 20 – 10 – 5 – 2.5 W (70 V) - 40 W (16 Ω)
MUSICAL POWER	80 W (16 Ω)
INPUT VOLTAGE	100 – 70 V
IMPEDANCE	- 16 Ω - 250 Ω (40 W – 100 V) - 500 Ω (20 W – 100 V) - 1 kΩ (10 W – 100 V) - 2 kΩ (5 W – 100 V)
CROSSOVER FREQUENCY	2 kHz
FILTER TYPE	6/6/6 dB/oct
COVERAGE ANGLE	180° horizontal, 60° (+20°, -40°) vertical
PROTECTION	PTC on tweeter
BODY	Self-extinguishing (HB level) high density polystyrene.
INPUT CONNECTOR	'Euroblock' terminal
MAX. INPUT CABLE WIRE SECTION	2.5 mm ²
USE	Indoor (outdoor only if protected)
DIMENSIONS (W, H, D)	120 mm, 510 mm, 130 mm
COLOUR	Black (MQ 100L); White (MQ 100L-W)
NET WEIGHT	4.2 kg

Except possible errors and omissions.
RCF S.p.A. reserves the right to make modifications without prior notice.

Salvo eventuali errori ed omissioni.
RCF S.p.A. si riserva il diritto di apportare modifiche senza preavviso.

HEADQUARTERS:

RCF S.p.A. Italy
tel. +39 0522 274 411
e-mail: info@rcf.it

RCF UK
tel. 0844 745 1234
Int. +44 870 626 3142
e-mail: info@rcfaudio.co.uk

RCF France
tel. +33 1 49 01 02 31
e-mail: france@rcf.it

RCF Germany
tel. +49 2203 925370
e-mail: germany@rcf.it

RCF Spain
tel. +34 91 817 42 66
e-mail: info@rcfaudio.es

RCF Belgium
tel. +32 (0) 3 - 3268104
e-mail: belgium@rcf.it

RCF USA Inc.
tel. +1 (603) 926-4604
e-mail: info@rcf-usa.com



www.rcfaudio.com