

Presentation:

The INSTALL SUB subwoofer series were designed to be an universally useable solution for installations seeking for a discrete but compact and effective subwoofer. Its bass reflex design is engineered to be as compact as possible while giving the maximum performance in terms of sound quality and bass response to any a PA installation.

The series comprises 4 models, IB 8 with a 8" (1.5in VC), IB12 with a 12" (2.95in VC), IB15 with a 15" (4in VC) and IB212 with 2x 12" (2.5in VC) all equipped with rubber surround EU transducers to provide excellent power density in compact enclosures.

This IB8A active version is driven by single channel premium quality EU class D amplifier featuring all electronic circuitry protection, with parallel XLR/M and XLR/F connectors for simple loop-through connectivity and a rotary potentiometer that allows to adjust the X-over frequency easily.

This INSTALL SUB series is the perfect partner to work with MOOSE INSTALL and LINEA series series acting as a supplement in PA installations to complete the existing sound with a deep and extended low frequency response, the ideal solution to any installed sound applications where space is limited allows close placement to any wall or corner.

The perfect solution for bars and restaurants, hotels, retail, etc.

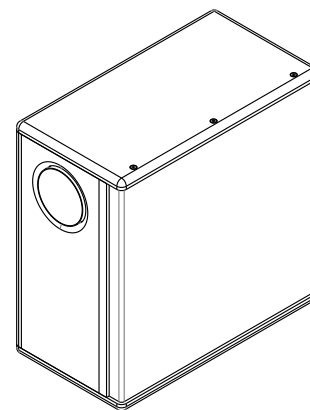

Features:

- Bass reflex installation subwoofer
- Available in passive/active versions
- 1x 8" (1.5in VC) LF EU transducer
- 320W rms class D, single channel amplifier
- 85-264Vac universal mains, SMPS, all electronic protections
- Variable X-over frequency adjustable by rotary pot
- Versatile, compact to permit unobtrusive placement
- Supplied with wallmount brackets
- Rugged and durable 15mm birch plywood construction
- Powder coated custom perforated steel grille

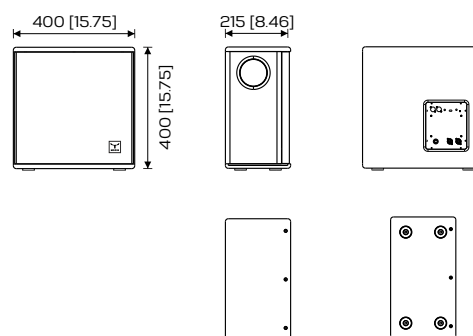

Technical specifications:

Dimensions in mm [in]

Acoustical

Type	Compact active subwoofer
Enclosure design	Bass reflex
Power rating (RMS/Peak)	200W / 400W
Frequency range	40 - 160Hz (-10dB)
Nominal impedance	8 ohm
Transducer type	1x 8" LF (1.5in VC) EU transducer
Crossover frequency	Adjustable by rotative potentiometer
SPL (1W/1kHz)	121dB @ 1m (peak)

Mechanical

Enclosure	15mm birch plywood, rugged polyurea coating
Grille	Custom perforated metal grilles w/ acoustic foam
Color	Black or white textured
Hardware	4 rubber feet Wallmount brackets (supplied)
Dimensions	400x215x400mm 15.75x8.46x15.75in
Weight	13Kg 28.67lb

Amplifier Module

Type	Single channel Class D
Output Power	320W / 8ohm
Internal Processing	Adjustable by rotative potentiometer
Audio input/output	XLR/F 3p XLR/M 3p
Indicators	Power, signal/preset, status, clip
Controls	Master level control, 4 selectable presets
AC Mains	SMPS with PFC, 85-264Vac universal mains
AC Mains connector	Neutrik® powerCON, Power-in/Power-out
Protections	Over current, short circuit, thermal, DC and HF