



(Shown with optional CVD desktop base)

Centraverse Gooseneck Microphone

The Shure Centraverse CVG is a professional gooseneck electret condenser microphone for use in general installed sound reinforcement applications. With dual gooseneck sections for full articulation, the CVG12/18 provides scalable, best-in-class performance in a wide variety of locations, including podiums and desktops.

Features

- Cardioid polar pattern with tailored response for speech
- Dual-section gooseneck enables ease of positioning and placement options
- Three model variations with inline preamps: standard, mute switch, and light ring indicator
- Available in 12" (30.4 cm) and 18" (45.7 cm) gooseneck lengths
- Commshield® technology guards against unwanted RF interference from portable wireless devices (smartphones, etc.)
- Included flange mount and snap-fit windscreen

Model Variations

CVG12RS-B/C

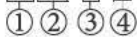

① Gooseneck Length

- 12: 12" gooseneck
- 18: 18" gooseneck

② Mute Button and LED Indicator*

- S: Includes mute button and bi-color LED on microphone body
- RS: Includes mute button and On/Off colored indicator ring
- *The Standard model does not feature a mute switch or LED

③ Color

- B: Black

④ Polar Pattern

- C: Cardioid

Note: Model availability depends on region. See your local Shure dealer or distributor for details.

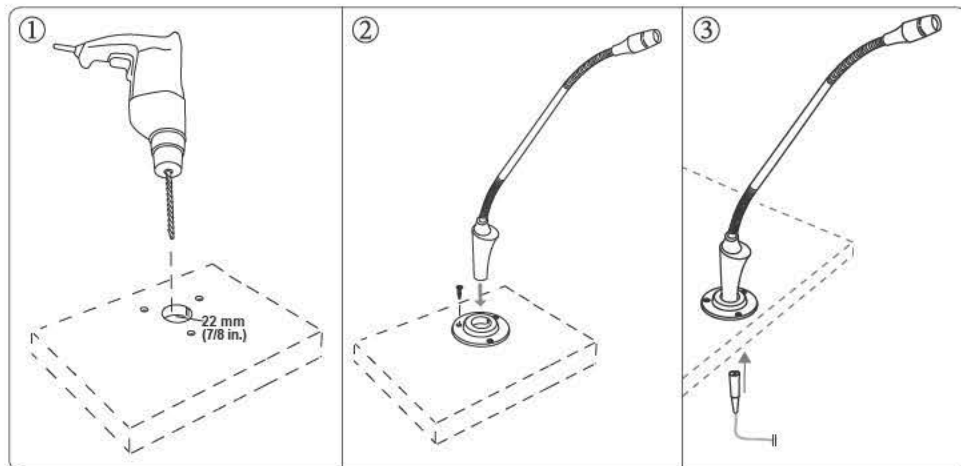

Installation

1. Drill a 22 mm (7/8 in.) hole in the mounting surface for the flange and three additional holes for the screws.
2. Screw the flange into place, and then set the microphone into the center hole.
3. Connect the microphone to a mixer or P.A. system using an XLR cable.

Note: This microphone requires +48V phantom power to operate.

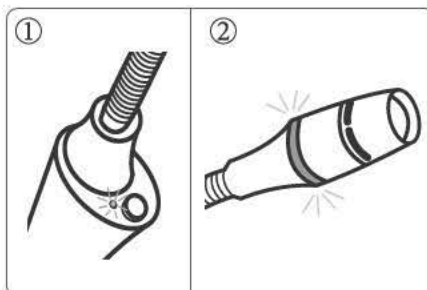

Mute Button Operation

Press the button on the microphone body to turn the mute on/off. The standard model does not feature a mute button.

1. CVG12S: Mute is indicated by an LED on the microphone body:
 - Green = Microphone is on
 - Red = Microphone is muted
2. CVG12RS: Mute is indicated by a light ring on the microphone head:
 - Red = Microphone is on
 - Off = Microphone is muted

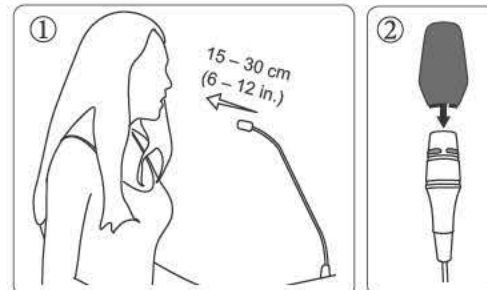

Guidelines For Use

1. Maintain a distance of approximately 15 - 30 cm (6 - 12 in.) between the sound source and the microphone.
2. Always use the supplied windscreen to control plosives and wind noise.

Specifications

Cartridge Type

Electret Condenser

Polar Pattern

Cardioid

Frequency Response

70–16000 Hz

Output Impedance

180 Ω

Sensitivity

open circuit voltage, @ 1 kHz, typical
–33 dBV/Pa[1] (22 mV)

Maximum SPL[2]

1 kHz at 1% THD
120 dB SPL

Signal-to-Noise Ratio[3]

Ref. 94 dB SPL at 1 kHz
67 dB

Dynamic Range

93 dB

Self Noise

equivalent SPL, A-weighted, typical
27 dB SPL

Preamp Output Clipping Level

@ 1 kHz, at 1% THD
–7 dBV

Common Mode Rejection

10 Hz to 100 kHz
>45 dB

Polarity

Positive pressure on diaphragm produces positive voltage on pin 2 with respect to pin 3

Environmental Conditions

Operating Temperature	–18 to 57°C (0 to 135°F)
Storage Temperature	–29 to 74°C (–20 to 165°F)
Relative Humidity	0 to 95%

Power Requirements

CVG	11–52 V DC[4], 2.0 mA
CVG/S	11–52 V DC[4], 5.5 mA
CVG/RS	11–52 V DC[4], 5.0 mA

Weight

CVG/12	6.3 oz. (177 g)
CVG/18	6.8 oz. (191 g)

[1] 1 Pa=94 dB SPL

[2] THD of microphone preamplifier when applied input signal level is equivalent to cartridge output at specified SPL

[3] S/N ratio is the difference between 94 dB SPL and equivalent SPL of self noise, A-weighted

[4] All specifications measured with a 48 Vdc phantom power supply. The microphone operates at lower voltages, but with slightly decreased headroom and sensitivity.

Accessories

Furnished Accessories

Windscreen	95A16670
Mounting Flange	RPM640

Optional Accessories

Desktop Base	CVD-B
Replacement Windscreens (4-pack)	ACVG4WS-B
Microphone Clip	A57F
25' XLR Cable	C25J
Shock Mount	A400SM

Certifications

Meets essential requirements of all applicable European Directives.

Eligible for CE marking.

The CE Declaration of Conformity can be obtained from Shure Incorporated or any of its European representatives. For contact information please visit www.shure.com

The CE Declaration of Conformity can be obtained from: www.shure.com/europe/compliance

Authorized European representative:

Shure Europe GmbH

Headquarters Europe, Middle East & Africa

Department: EMEA Approval

Jakob-Dieffenbacher-Str. 12

75031 Eppingen, Germany

Phone: 49-7262-92 49 0

Fax: 49-7262-92 49 11 4

Email: EMEAsupport@shure.de

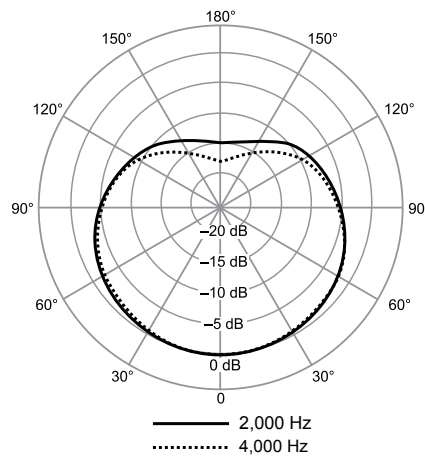
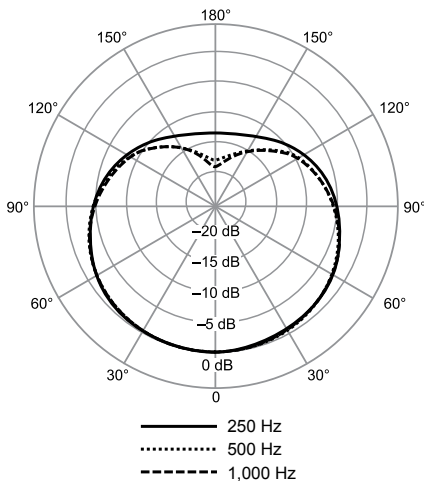
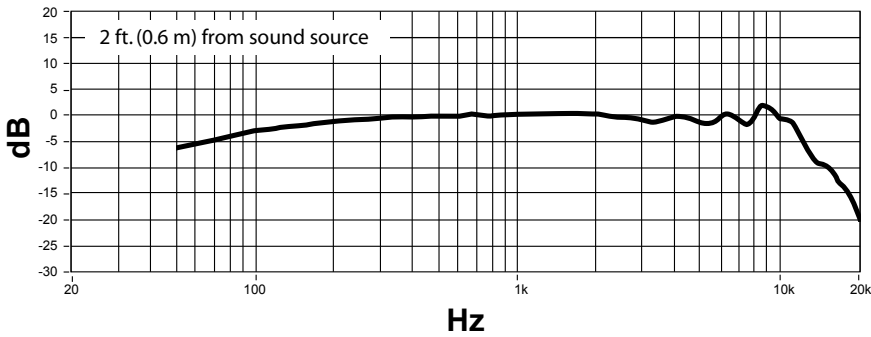

SHURE®

SHURE Incorporated <http://www.shure.com>
United States, Canada, Latin America, Caribbean:
5800 W. Touhy Avenue, Niles, IL 60714-4608, U.S.A.
Phone: 847-600-2000 U.S. Fax: 847-600-1212 Int'l Fax: 847-600-6446
Europe, Middle East, Africa:
Shure Europe GmbH, Phone: 49-7262-92490 Fax: 49-7262-9249114
Asia, Pacific:
Shure Asia Limited, Phone: 852-2893-4290 Fax: 852-2893-4055