



***KRM33***  
**USER'S GUIDE**  
*English*





## CONTENTS

<b>1. INTRODUCTION</b>	<b>6</b>
<b>2. APPLICATIONS</b>	<b>6</b>
<b>3. KEY FEATURES</b>	<b>6</b>
<b>4. UNPACKING</b>	<b>7</b>
<b>5. PACKAGE CONTENT</b>	<b>7</b>
<b>6. SAFETY</b>	<b>8</b>
<b>7. PHYSICAL</b>	<b>10</b>
<b>8. AMPLIFIER</b>	<b>11</b>
<b>8.1 AC POWER CONNECTOR</b>	<b>11</b>
<b>8.2 VOLTAGE REQUIREMENT</b>	<b>11</b>
<b>8.3 CURRENT REQUIREMENT</b>	<b>11</b>
<b>8.4 REAR PANEL</b>	<b>12</b>
<b>8.5 AUDIO INPUT CONNECTOR WIRING</b>	<b>13</b>
<b>8.7 AMPLIFICATION AND PROTECTION CIRCUITRY</b>	<b>13</b>
<b>9. K-FRAMEWORK</b>	<b>14</b>
<b>10. COVERAGE</b>	<b>15</b>
<b>11. ACCESSORIES AND CONFIGURATIONS</b>	<b>17</b>
<b>12. SERVICE</b>	<b>19</b>
<b>13. SPECIFICATIONS</b>	<b>20</b>
<b>14. DISPERSION DIAGRAMS</b>	<b>21</b>
<b>15. DECLARATION OF CONFORMITY</b>	<b>22</b>



## SYMBOLS

---



K-array declares that this device is in compliance with applicable CE standards and regulations. Before putting the device into operation, please observe the respective country-specific regulations!

---



### WEEE

Please dispose of this product at the end of its operational lifetime by bringing it to your local collection point or recycling center for such equipment.

---



This symbol alerts the user to the presence of recommendations about the product's use and maintenance.

---



Warning! Dangerous voltages: RISK of electric shock.

Terminals marked with this symbol are HAZARDOUS LIVE and the external wiring connected to these terminals requires installation by an instructed person or the use of ready-made leads or cords.

---



This symbol alerts the user to the presence of recommendations about product's use and maintenance.

---



This device complies with Restriction of Hazardous Substances Directive.

---

## 1. INTRODUCTION

The KRM33 or “the cheese box” as it has been affectionately nicknamed, is an ultra-compact and low-profile powered wedge speaker with a controlled horizontal pattern and has an extended frequency response. It is made up of three 3.15” cone drivers and one 6” passive radiator. This combination guarantees a controlled and linear emission on a really wide range, with a bass enhancement mode that can go from 70Hz to 18KHz.

The KRM33 is equipped with a two channel amplifier and a DSP that can be used to adjust the EQ directly inside the box. An USB direct connection guarantees an easy plug & play connection. The DSP also offers the possibility of changing the horizontal pattern of the single speaker and its bass response, two buttons located at the back of the box are used to quickly change these settings without the need of a computer.

The controlled horizontal dispersion gives the possibility of creating horizontal arrays which increase the SPL and the coverage while maintaining a high and constant signal-before-feedback within all the cluster’s beams.

The stainless steel chassis is a sturdy and durable box solution which is also remarkably short in height. Thanks to this feature the KRM33 can be easily and discreetly integrated in scenography designs, broadcast studios as well as under-balcony speakers in theaters.

All the components of the Redline KRM33 are designed by the K-array R&D department and made in Italy under the K-array quality control system.

## 2. APPLICATIONS

- Arrayable wedge monitor
- ceiling and under-balcony speaker;
- corporate installations;
- house of worship;
- small clubs;
- theatrical sound reinforcement.

## 3. KEY FEATURES

- Selectable horizontal coverage;
- extended frequency response;
- strong stainless steel chassis;
- controlled horizontal dispersion.

## 4. UNPACKING

Each K-array loudspeaker is built to the highest standard and thoroughly inspected before leaving the factory. Upon arrival, carefully inspect the shipping carton, then examine and test your new loudspeaker. If you find any damage, immediately notify the shipping company. Only the consignee may institute a claim procedure regarding the system's electronic equipment.

## 5. PACKAGE CONTENT



## 6. SAFETY



WARNING



Read all safety information below and operating instructions before using this device to avoid injury.

### Safety and handling information



**Warning.** Failure to follow these safety instructions could result in fire, shock or other injury or damage to the device or other property.

*It is important that loudspeaker systems are used in a safe manner.*

**Avoiding Hearing Damage.** Professional loudspeakers are capable of producing extremely high sound levels and should be used carefully. Never stand close to loudspeakers driven at high volume. Set the volume to a safe level. Over time you can adapt to a higher volume of sound that may sound normal but can be damaging to your hearing. Hearing loss gets worse every time you're exposed to a sound level of 90 dB or over for an extended period of time. If you experience ringing in your ears or muffled speech, stop listening and have your hearing checked. The louder the volume, the less time is required before your hearing could be affected.

**Choking Hazards.** This device contains small parts, which may present a choking hazard to small children. Keep the device and its accessories away from small children.

**Avoiding Water and Wet Locations.** Do not install the system in wet or humid locations without using weather protection. Take care not to spill any food or liquid on the device. In case it gets wet, unplug all cables, turn off the device before cleaning, and allow it to dry thoroughly before turning it on again. Do not attempt to dry the device with an external heat source, such as a microwave oven or hair dryer. A device that has been damaged as a result of exposure to liquids could be not serviceable. If the device is exposed to rain or excess moisture, unplug the power cord immediately.

**Keeping the Outside Clean.** Handle the device with care to maintain its appearance. To clean it, unplug all cables and turn it off. Warning: unplugging the power cord is the only way to disconnect the power completely. Then use a soft, dry or slightly damp cloth. Avoid getting moisture in the openings. Don't use window cleaners, household cleaners, aerosol sprays, solvents, alcohol, ammonia, or abrasives to clean the device.

**Carrying, Handling and Installing the device.** The device contains sensitive components. Do not drop, disassemble, open, crush, bend, deform, puncture, shred, microwave, incinerate, paint, or insert foreign objects into it. If your device has been dropped or damaged, or if liquid has been spilled into the chassis, unplug the power cord immediately.

Do not operate speakers for an extended period of time with sound distortion. This is an indication of malfunction, which in turn can generate heat and result in a fire.

To reduce the risk of overheating the device, avoid exposing it to direct sunlight and take care to do not



install it near heat emitting appliances, such as a room heater or stove.

No naked flame sources such as lighted candles should be placed near the device.

Operate the device in a place where the temperature is between -20°C and 50°C (-4°F to 122° F). Avoid dramatic changes in temperature or humidity when using it, as condensation may form on or within the device.

During the use, it is normal for the device to get warm. The exterior of the device functions as a cooling surface that transfers heat from inside the unit to the cooler air outside.

The device should be placed so that its location does not interfere with its proper cooling. For example, the device shouldn't be placed on beds, carpets or similar surfaces that could create an obstacle for the ventilation openings.

To reduce the risk of electric shock, unplug the power cord before connecting audio cables.

Set up your device on a stable horizontal surface. If combined or mechanically connected with other products, always verify the stability of the system set up. Install the unit only in a location that can structurally support the weight of the unit, far away from people who can interfere with the stability of the system. In case of outdoor installation, assure that the wind does not interfere with the system's stability, taking extra securities like chains, weights, ropes or any other certified anchoring systems. Doing otherwise may result in the unit falling down, causing personal injury or property damage. Doing otherwise may result in the unit falling down, causing personal injury or property damage. The system should only be suspended by qualified personnel following safe rigging practices. Secure fixings to the building structure are vital. To clarify any doubt you may have, seek help from architects, structural engineers or other specialists.

Protect the power cord from being walked on or pinched.

This audio system is not intended for use in the operation of nuclear facilities, aircraft navigation or communication systems, air traffic control systems, or for any other uses where the failure of the audio system could lead to death, personal injury, or sever environmental damage.

**Do not make repairs yourself.** Caution, risk of electric shock. Do not open the device, it contains potentially hazardous voltage. Never attempt to disassemble, repair or modify the system yourself.

Disassembling the unit may cause damage that is not covered under the warranty. The device contains no user-serviceable parts. Repairs should only be performed by factory trained service personnel. Do not plug the power cord if you suspect that your device needs service or repair.

**Voltage requirement.** Make sure that the supplied voltage stays within the specified range. Verify that your mains connection satisfies the power ratings of the device.

Only connect the power supply to an appropriate power outlet.

Warning: The device must be only connected to an AC three-wire grounding outlet. If your outlet isn't grounded, contact a licensed electrician to replace it with a property grounded outlet.



Warning: connecting the system to an AC power mains with a voltage exceeding 270 V will cause significant damage to the device and create a serious risk for users!



The devices which feature powerCON connectors allow power supply to other devices from the white outlet socket. The maximum power value which can be picked up from that socket changes according to the device model. Please, read the user manual carefully.

# 7. PHYSICAL

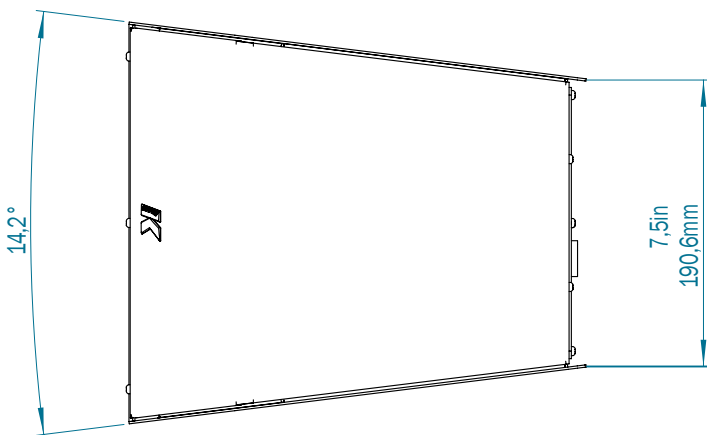
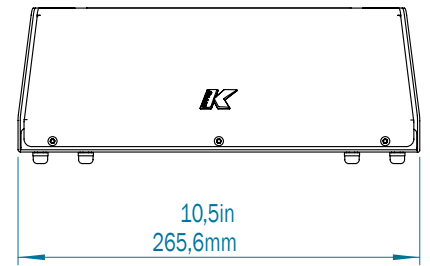
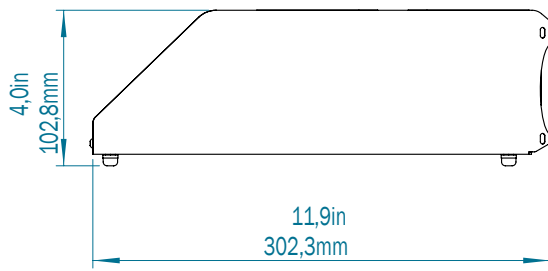
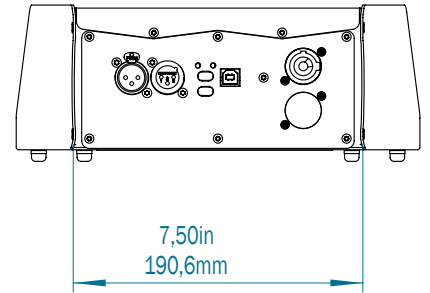
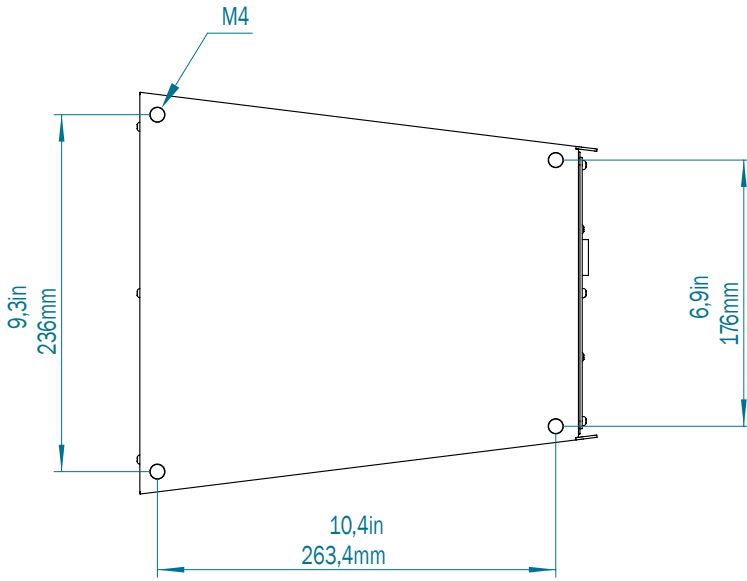

WEIGHT: 5,2 Kg  
11,5 lb

## 8. AMPLIFIER

### 8.1 AC POWER CONNECTOR

The amplifier module and any audio equipment connected to it (mixing consoles, processors, etc.) must be properly connected to the AC power distribution, preserving AC line polarity. All grounding points should be connected to a single node or common point, using the same cable gauge as the neutral and line cables. Bad grounding connections within an audio system can produce noise, hum and/or serious damage to the input/output stages in the system's electronic equipment.



Before applying AC to any K-array self-powered speaker, be sure that the voltage potential difference between neutral and earth ground is less than 5 VAC.

### 8.2 VOLTAGE REQUIREMENT

The KRM33 will operate safely, without interruption, provided the AC voltage remains within 85V - 268V, at 50 or 60 Hz. Please verify that your AC mains connection is capable of satisfying the power ratings for the device.



#### CAUTION

Do not connect the system to AC power mains exceeding 270V. Doing so will cause significant damage to the device and create serious risk for users!

### 8.3 CURRENT REQUIREMENT

The KRM33 presents a dynamic load to the AC mains, drawing additional current as operating levels increase. Different cables and circuit breakers heat up at varying rates, so it is essential to understand current ratings and how they correspond to circuit breaker and cable specifications. Maximum continuous RMS current - measured over a period of at least ten seconds - is used to calculate the temperature increase in cables, which drives the proper size and gauge cable and rating for slow-reacting thermal breakers. Maximum burst RMS current - measured over a period of approximately one second - is used to select the rating for fast reacting magnetic breakers.

For best performance, voltage drops should not exceed 10% at 115V or 5% at 230V.

The minimum electrical service amperage required by a K-array loudspeakers system is the sum of their maximum continuous RMS current. We recommend allowing an additional 30% above the minimum amperage to prevent peak voltage drops at the service entry.

**KRM33 max continuous apparent power (W)**  
**230W(>10 sec) - 660W (<1 sec)**

## 8.4 REAR PANEL

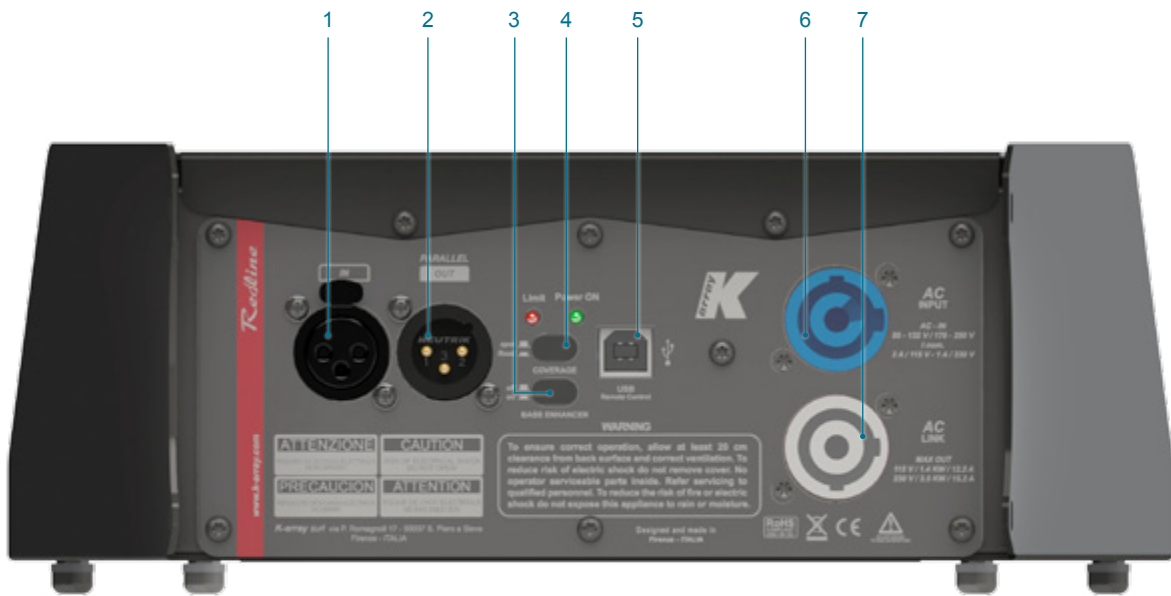

img. 1

- 1) XLR balanced input;
- 2) XLR parallel balanced output;
- 3) Bass Enhancement switch button. When button is pressed, bass enhancement is ON and the frequency response of the speaker extends down to 60Hz;
- 4) Coverage switch button. This button switches between Spot and Flood coverage. When button is pressed, Flood mode is active;
- 5) USB socket for remote EQ adjustment and firmware updates (K-framework management software);
- 6) PowerCon input;
- 7) PowerCon link output.

## 8.5 AUDIO INPUT CONNECTOR WIRING

The Audio section includes parallel LINK, which allows users to distribute an audio signal to multiple units. Up to 30 different modules can be connected in parallel on the same balanced line (with a source output impedance of 600 ohm).

CH 1 Line Input (female, balanced XLR) is wired in parallel to CH1 Line Parallel Out (male, balanced XLR). To create your own audio cables, please use the following wiring diagrams:

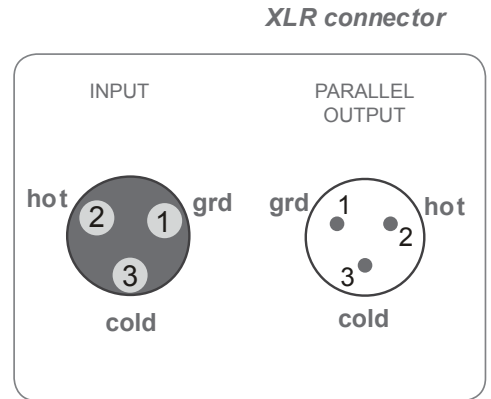

*img. 2*

## 8.7 AMPLIFICATION AND PROTECTION CIRCUITRY

The KMR33 is powered by a 2-channel digital amplifier with 2 x 125W @4Ω output power per channel (EIAJ test).

The KRM33's amplifier functions, including crossovers, equalization and phase response are controlled by an on-board DSP processor.

KRM33's amplifier is equipped with several protection circuits to prevent damage. Two independent audio limiters – Clip Limiter and Average Power Limiter – protect the internal circuitry against overload. A Peak Current Shut Down protects the output stage. If tripped, Peak Current Shut Down will reset after 2 seconds. A Temperature Protection Limiter also ensures the output stage stays below a temperature of 85° C (approximate temperature of output power device).

## 9. K-FRAMEWORK

K-framework is a management software for K-array speaker systems.

Version 1.8 is enabled to also manage the KRM33 as well.

Be sure you have the latest version of K-framework installed on your personal computer also in order to keep all systems firmware and preset banks up to date.

To download your free K-Framework software, please navigate to the K-array “[Software Download](http://www.k-array.com/en/download/software.html)” page located at <http://www.k-array.com/en/download/software.html>

Download the latest 32- or 64-bit installer. Decompress the .zip file and extract the “K-Framework.setup” installer file.

- Windows Vista and Windows 7 users can install the software by simply running the K-Framework.setup file.
- Windows XP users are required to install the necessary USB drivers separately:

### SYSTEM REQUIREMENTS:

Operating System: Windows XP / Vista / 7 / 8

CPU: Intel Pentium Dual Core

Memory: 2 GB

### REQUIRED COMPONENTS:

Microsoft .NET Framework 4

Microsoft Visual C++ 2010 Redistributable Package (x86)

Microsoft Visual C++ 2010 Redistributable Package (x64)

## 10. COVERAGE

KRM33 provides two different coverage settings in order to meet different operating needs.

- Flood setting (70°) widens horizontal dispersion ([img. 3](#)) and is suggested for single speaker applications.
- Spot setting (30°) is suggested when a narrow coverage is needed ([img. 4](#)) and when KRM33 is used in array configuration with other KRM33 ([img. 5 & 6](#)).

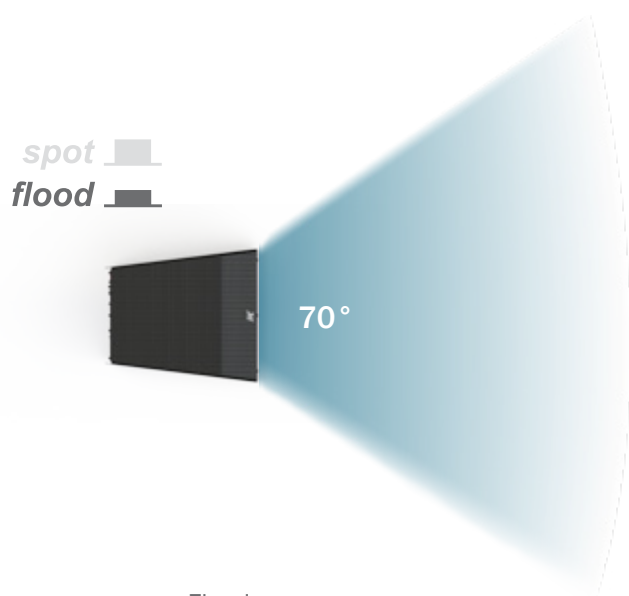

[img. 3](#): Flood coverage

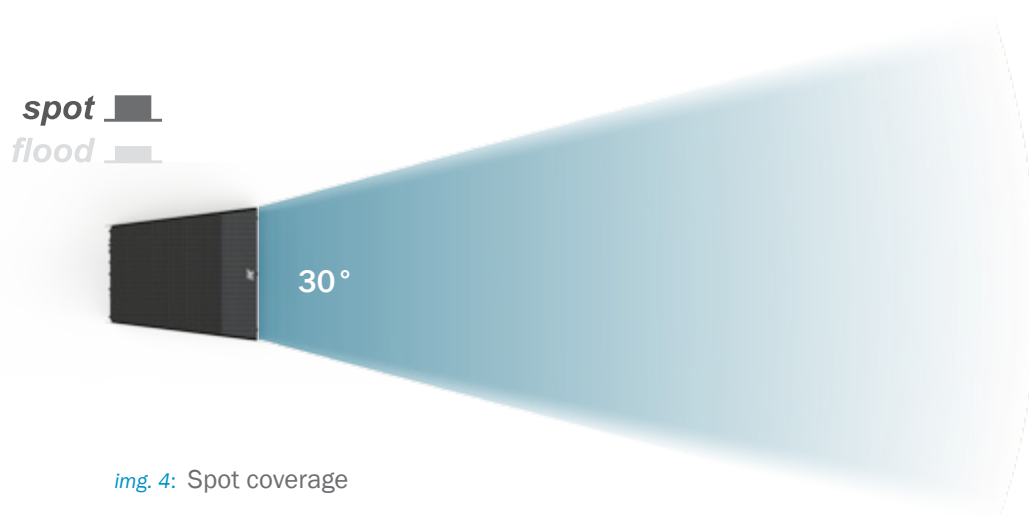

[img. 4](#): Spot coverage

**spot**   
**flood** 



img. 5

**spot**   
**flood** 

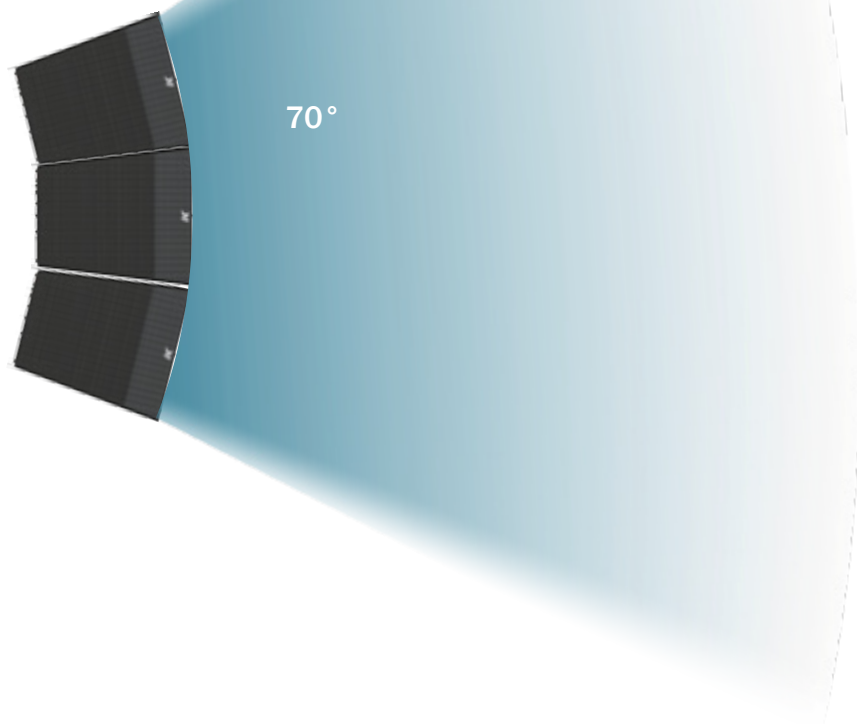

img. 6



## 11. ACCESSORIES AND CONFIGURATIONS

### K-R3WALL1

The K-R3WALL1 mounting accessory is designed to fasten KRM33 and KRM33P on walls and ceilings.



WARNING



Before connecting KRM33/KRM33P speakers to a K-3WALL1, check the stability of the surface where K-3WALL1 is to be fixed to.

The K-3WALL1 should not be placed in a zone accessible to the audience.

Please, read the K-3WALL1's user manual and follow the mounting instruction.

The KRM33, or KRM33P, can be installed as a ceiling speaker to create a PA system in low clearance rooms.

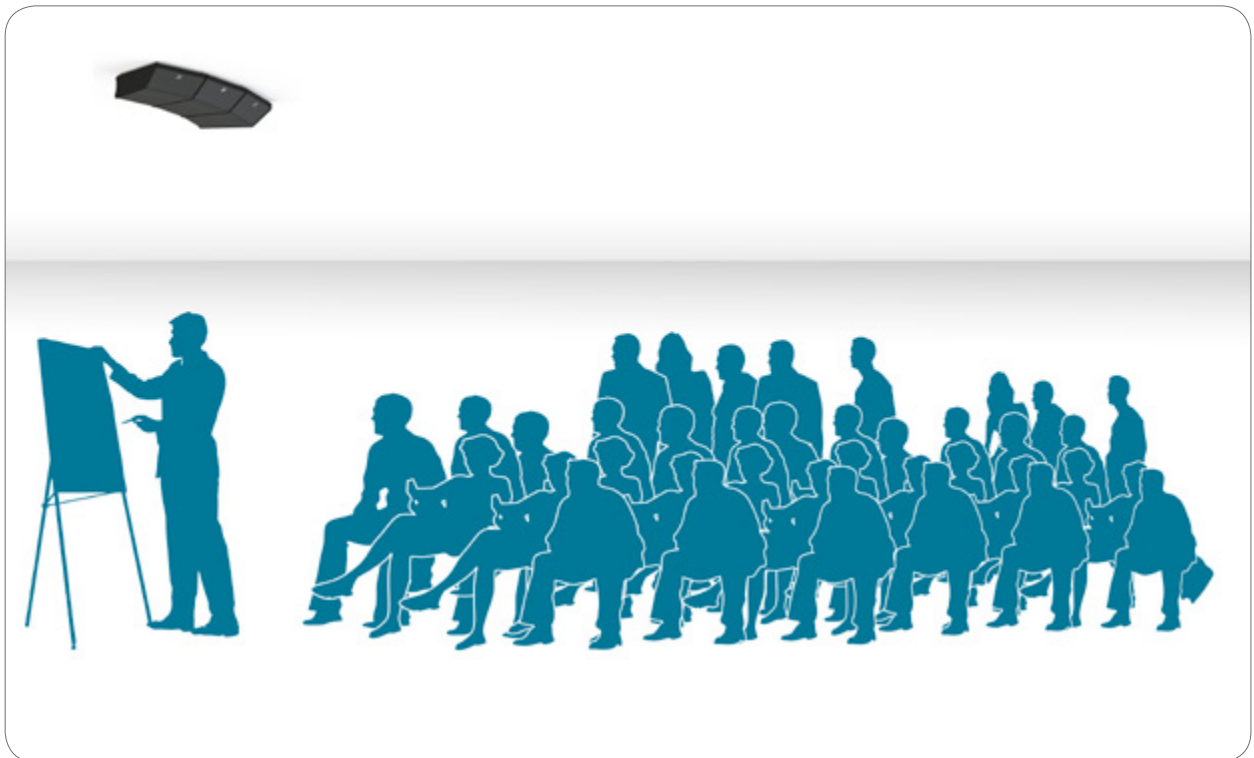

img. 7

The KRM33, or KRM33P, can be used on small and medium live stages as floor monitor. The controlled horizontal pattern allows to manage easily coverage and SPL for different needs.



img. 8

## 12. SERVICE

To obtain service:

- 1) Contact the official K-array distributor in your country. Your local distributor will direct you to the appropriate service center.
- 2) If you are calling for service, please have the serial number(s) of the unit(s) available for reference. Ask for Customer Service, and be prepared to describe the problem clearly and completely.
- 3) If the problem cannot be resolved over the phone, you may be required to send the unit in for service. In this instance, you will be provided with an RA (Return Authorization) number which should be included on all shipping documents and correspondence regarding the repair. Shipping charges are the responsibility of the purchaser.

Any attempt to modify or replace components of the device will invalidate your warranty. Service must be performed by an authorized K-array service center.



Cleaning:

Use only a soft, dry cloth to clean the housing. Do not use any solvents, chemicals, or cleaning solutions containing alcohol, ammonia, or abrasives. Do not use any sprays near the product or allow liquids to spill into any openings.

# 13. SPECIFICATIONS

## KRM33 specs

	<b>Acoustics</b>
<b>Speaker power handling</b>	180 W <sup>(AES)</sup>
<b>Frequency range</b>	70 Hz – 20 KHz +/- 3dB <sup>(1)</sup> / 100 Hz – 20 KHz +/- 3dB <sup>(2)</sup>
<b>SPL 1W/1mt</b>	93 dB
<b>Maximum SPL</b>	115 dB (cont.) – 121 dB (peak)
	<b>Coverage</b>
<b>Horizontal</b>	DSP controlled (30° / 70° selectable)
<b>Vertical</b>	90°
	<b>Crossover</b>
<b>Type</b>	DSP controlled
<b>Frequency</b>	70 Hz minimum (preset dependent)
	<b>Transducers</b>
	3 X 3,15" Neodymium cone driver with 1" voice coil 1 X 6" passive radiator
	<b>Selection Switch</b>
<b>Horizontal pattern</b>	Spot – Flood
<b>Response</b>	Bass Enhancer
	<b>Audio Input</b>
<b>Analog connector</b>	1 male + 1 female 3-pin balanced XLR
	<b>Remote Control Input</b>
<b>Connector</b>	1 USB type B
	<b>Power Input</b>
<b>Connector</b>	2 x PowerCon IN/OUT
	<b>Amplifier</b>
<b>Type</b>	1 module class D - DSP controlled
<b>Nominal power output</b>	2 X 125 W @ 4 Ω 1% THD + NOISE
<b>Protection</b>	Dynamic limiter - Over current - Short circuit
<b>Frequency response</b>	20 Hz – 20 KHz, all load +/- 0.5 dB
<b>Damping factor 8Ω, 100 Hz</b>	> 500
<b>THD+N 1KHz, 1 W</b>	0.003%
	<b>AC Power</b>
<b>Nominal voltage</b>	115 / 230 Vac auto switching
<b>Operating range</b>	85 – 132 Vac 170 – 264 Vac 50 – 60 Hz
<b>I. Nom</b>	2 A / 115 Vac 1 A / 230 Vac
	<b>Consumption</b>
<b>Quiescent power (with no signal in)</b>	10 W
<b>1/8 rated power (pink noise) @ 4 Ω</b>	110 W
<b>Peak power</b>	660 W / 120 ms
	<b>Certification</b>
<b>IP</b>	40
	<b>Physical</b>
<b>Dimensions</b>	26.6 x 10.3 x 3.02 cm (10.47" x 4.06" x 11.89")
<b>Weight</b>	5.2 Kg (11.59 lbs)

*Notes for data*

1. Bass enhancer ON.
2. Bass enhancer OFF.

New materials and design are introduced into existing products without previous notice. Present systems may differ in some respects from those presented in this catalogue.

# 14. DISPERSION DIAGRAMS

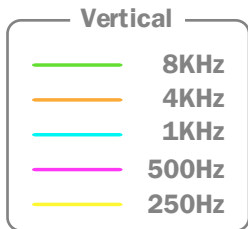
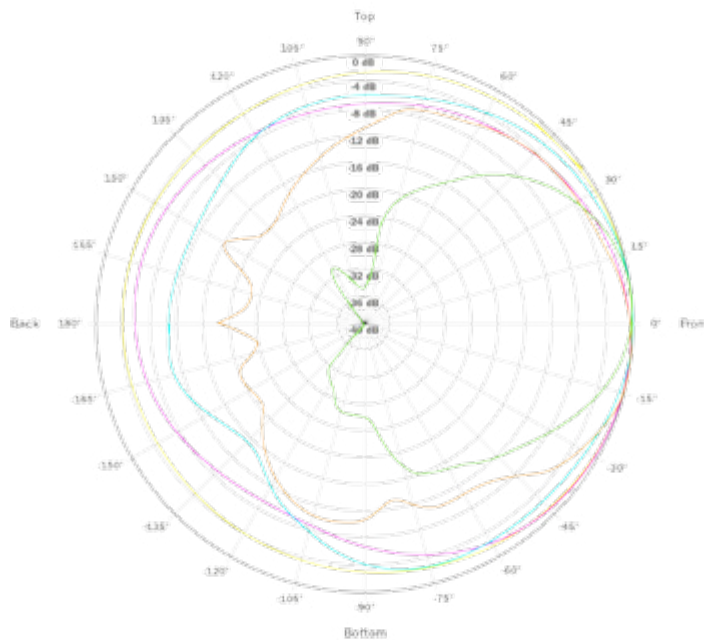
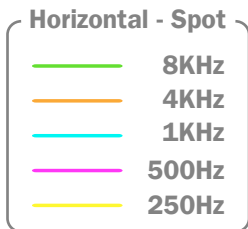
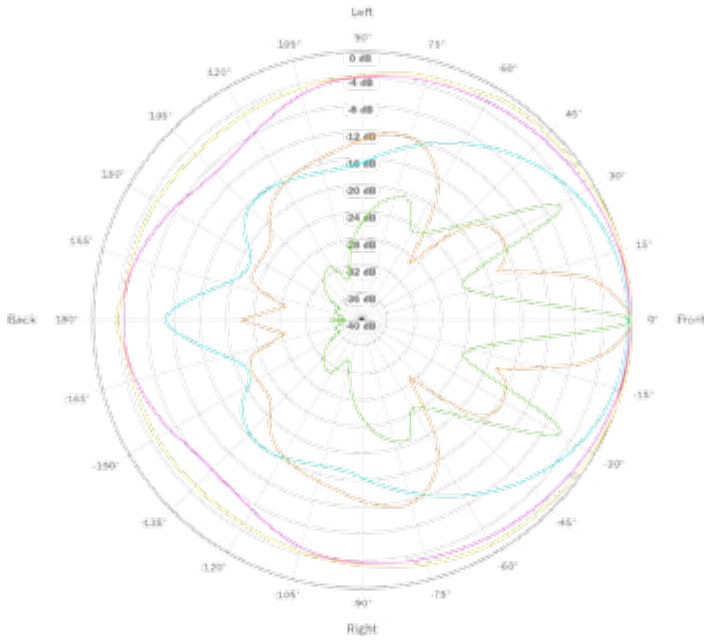
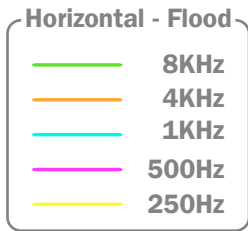
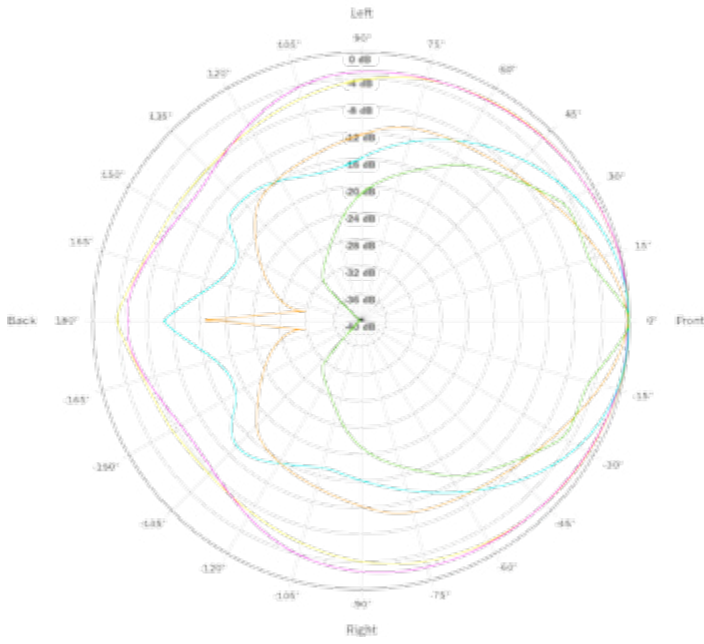

# 15. DECLARATION OF CONFORMITY

**Manufacturer/Importer:** K-array s.u.r.l.

**Brand:** K-ARRAY

**Address:** via Paolina Romagnoli 17 50037 S. Piero a Sieve Firenze ITALY

**Date of Issue:** 10 / 01 / 13

**Model Code:** KRM33

**Declaration:** Complies with safety essential requirements of Council Directive

2004/108/EC on the approximation of the Laws of the Member States relating to electromagnetic compatibility.

2006/95/EC on the harmonisation of the laws of member state relating equipment designed for the use within certain voltage limits

This declaration applies to all specimens manufactured in accordance with the attached manufacturing drawings which form part of this declaration. Assessment of compliance of the product with the requirements relating to electromagnetic compatibility and low voltage directive was based on the following standards:

EMC:

EN 55103-1:2009  
EN 55103-2:2009  
EN 61000-3-2:2006+A1+A2  
EN 61000-3-3:2008

Safety:

EN 60065:2002+A1+A11+A2+A12

**Marking:**



**Applying Year:**

2013

**Applied by:**

K-array s.u.r.l.

Via Paolina Romagnoli 17  
50037 S. Piero a Sieve  
Firenze Italy  
Tel. +39 055 8487222  
Fax +39 055 8487238

**Signed by:**

**Franco Spataro**

Technical Manager

The contents of this manual are furnished for informational purposes only. K-array srl assumes no responsibility for any errors or inaccuracies that may appear in this manual. K-array reserves the right to make modifications without prior notice.



**K-array** s.r.l. unipersonale

Via Paolina Romagnoli - 50037  
San Piero a Sieve (Firenze) - Italy  
tel. +39 055 8487222 - fax. +39 0558487238  
e-mail: [info@k-array.com](mailto:info@k-array.com)  
[www.k-array.com](http://www.k-array.com)